

MOTOTRBO™ MTR3000

Base Station/Repeater

Installation and User Manual



Foreword

This manual is intended for use by experienced technicians familiar with similar types of equipment. Specifically, it contains installation information required for the MTR3000 Base Station/Repeater.

For information related to the service of the MTR3000 Base Station/Repeater, refer to the list of applicable manuals available separately. This list is provided in the Related Publications on page xiv.

General Safety Precautions

See "General Safety and Installation Standards and Guidelines" on page ii.

Manual Revisions

Changes which occur after this manual is printed are described in PMRs (Publication Manual Revisions). These PMRs provide complete replacement pages for all added, changed, and deleted items. Go to the following web sites according to regions to obtain PMRs:

Europe, Middle East and Africa (EMEA): <https://emeaonline.motorola.com>

Latin America (LACR) and North America (NAG): <http://www.motorola.com/businessonline>

Parts Ordering

See "Appendix A", "Appendix C" or "Appendix D" for information on how to obtain replacement parts. For part numbers, refer to the MOTOTRBO MTR3000 Base Station/Repeater Basic Service Manual (Motorola publication part number 68007024096).

Computer Software Copyrights

The Motorola products described in this manual may include copyrighted Motorola computer programs stored in semiconductor memories or other media. Laws in the United States and other countries preserve for Motorola certain exclusive rights for copyrighted computer programs, including, but not limited to, the exclusive right to copy or reproduce in any form the copyrighted computer program. Accordingly, any copyrighted Motorola computer programs contained in the Motorola products described in this manual may not be copied, reproduced, modified, reverse-engineered, or distributed in any manner without the express written permission of Motorola. Furthermore, the purchase of Motorola products shall not be deemed to grant either directly or by implication, estoppel, or otherwise, any license under the copyrights, patents or patent applications of Motorola, except for the normal non-exclusive license to use that arises by operation of law in the sale of a product.

Document Copyrights

No duplication or distribution of this document or any portion thereof shall take place without the express written permission of Motorola. No part of this manual may be reproduced, distributed, or transmitted in any form or by any means, electronic or mechanical, for any purpose without the express written permission of Motorola.

Disclaimer

The information in this document is carefully examined, and is believed to be entirely reliable. However, no responsibility is assumed for inaccuracies. Furthermore, Motorola reserves the right to make changes to any products herein to improve readability, function, or design. Motorola does not assume any liability arising out of the applications or use of any product or circuit described herein; nor does it cover any license under its patent rights nor the rights of others.

Trademarks

MOTOROLA and the Stylized M Logo are registered in the U.S. Patent and Trademark Office. All other product or service names are the property of their respective owners.

© 2010 by Motorola, Inc. All rights reserved.

General Safety and Installation Standards and Guidelines

 <p>WARNING</p>	<p>WARNING: For safe installation, operation, service and repair of this equipment, follow the safety precautions and instructions described below, as well as any additional safety information in Motorola's product service and installation manuals and the Motorola R56 Standards and Guidelines for Communications Sites manual (6881089E50). To obtain copies of these materials, please contact Motorola as directed at the end of this section. After installation, these instructions should be retained and readily available for any person operating or servicing this base station/repeater or working near it.</p> <p>Failure to follow these safety precautions and instructions could result in serious injury or property damage.</p> <p>The installation process requires preparation and knowledge of the site before installation begins. Review installation procedures and precautions in the Motorola R56 manual before performing any site or component installation. Personnel must use safe work practices and good judgment, and always follow applicable safety procedures, such as requirements of the Occupational Safety and Health Administration (OSHA), the National Electrical Code (NEC), and local codes.</p>
--	--

The following are additional general safety precautions that must be observed:

- To continue compliance with any applicable regulations and maintain the safety of this equipment, do not install substitute parts or perform any unauthorized modifications.
- All equipment must be serviced by Motorola trained personnel.
- If troubleshooting the equipment while the power is on, be aware of live circuits which could contain hazardous voltage.
- Do not operate the radio transmitters unless all RF connectors are secure and all connectors are properly terminated.
- All equipment must be properly grounded in accordance with the Motorola R56 and specified installation instructions for safe operation.
- Slots and openings in the cabinet are provided for ventilation. Do not block or cover openings that protect the devices from overheating.
- Some equipment components can become extremely hot during operation. Turn off all power to the equipment and wait until sufficiently cool before touching.
- Maintain emergency first aid kits at the site.
- Never store combustible materials in or near equipment racks. The combination of combustible material, heat and electrical energy increases the risk of a fire hazard.
- Equipment shall be installed in a site that meets the requirements of a "restricted access location," per (UL60950-1 & EN60950-1), which is defined as follows: "Access can only be gained by service persons or by users who have been instructed about the reasons for the restrictions applied to the location and about any precautions that shall be taken; and access is through the use of a tool or lock and key, or other means of security, and is controlled by the authority responsible for the location."
- Burn hazard. The metal housing of the product may become extremely hot. Use caution when working around the equipment.

- RF energy burn hazard. Disconnect power in the cabinet to prevent injury before disconnecting and connecting antennas.
- Shock hazard. The outer shields of all Tx and Rx RF cables outer shields must be grounded per Motorola R56 manual.
- Shock hazard. DC input voltage shall be no higher than 60 VDC. This maximum voltage shall include consideration of the battery charging "float voltage" associated with the intended supply system, regardless of the marked power rating of the equipment.
- All Tx and Rx RF cables shall be connected to a surge protection device according to Motorola R56 manual. Do not connect Tx and Rx RF cables directly to an outside antenna.
-  Compliance with National and International standards and guidelines for human exposure to Electromagnetic Energy (EME) at Transmitter Antenna sites generally requires that persons having access to a site shall be aware of the potential for exposure to EME and can exercise control of exposure by appropriate means, such as adhering to warning sign instructions. See this installation manual and Appendix A of Motorola R56.

This product complies with the requirements set forth by the European R&TTE regulations and applicable CENELEC standards concerning human exposure to Electromagnetic Energy (EME) at Transmitter Antenna sites. "Appendix E" in this manual includes an EME exposure analysis of a typical system configuration for this product.

For a different system configuration than the typical configuration, compliance with applicable EME exposure standards (current versions of the EN50384 and EN50385 standards for occupational and general public exposure, respectively) can be evaluated by either employing the method illustrated in the typical system configuration EME exposure analysis included in "Appendix E" in this manual, or employing another suitable method among those described in the current version of the EN50383 standard.

Once the occupational and general public compliance boundaries are determined, means to ensure that workers and people are outside the respective boundaries, for instance using appropriate signage or restricted access, should be implemented; if this is not possible or practically achievable for the specific system configuration, the configuration should be modified in order to make it possible. The R56 Standards and Guidelines for Communications Sites (6881089E50) manual provides examples of signage that can be used to identify the occupational or general public compliance boundaries.

Refer to product specific manuals for detailed safety and installation instructions. Manuals can be obtained with product orders, downloaded from <http://www.motorola.com/businessonline>, or purchased through the Motorola Aftermarket & Accessory Department.

 WARNING	This is a class A product. In a domestic environment, this product may cause radio interference in which case the user may be required to take adequate measures.
--	--

MOTOTRBO MTR3000 Base Station/Repeater Supplemental Safety and Installation Requirements

ATTENTION!

The MOTOTRBO MTR3000 Base Station/Repeater must be installed in a suitable, in-building enclosure. A restricted access location is required when installing this equipment into the end system.

The base station/repeater contains a Class 1 built-in power supply component. It is equipped with an appliance inlet for connecting to an AC input, as well as DC input terminals which meet SELV DC circuit requirements.

When installing the equipment, all requirements of relevant standards and local electrical codes must be fulfilled.

The maximum operating ambient temperature of this equipment is 60°C. The maximum operating altitude is 3000 meters above sea level.

The 28.6 VDC output from the power supply to the PA is at an energy hazard level (exceeds 240 VA). When installing into the end system, care must be taken so as not to touch the output wires.

When the MOTOTRBO MTR3000 Base Station/Repeater is used in a DC reverting system, the DC power supply must be located in the same building as the MOTOTRBO MTR3000 Base Station/Repeater, and it must meet the requirements of a SELV circuit.

Environmental Information

Material Content

NOTE: The Motorola MOTOTRBO MTR3000 Base Station/Repeater system and its subsystems have been created in compliance with the environmental goals of the European Union's **Restriction of Hazardous Substances (RoHS)** and the **Waste Electrical and Electronic Equipment (WEEE)** Directive 2002/96/EC as well as Motorola's corporate goals to minimize environmental impact of its products.

This Motorola policy is reflected throughout the entire design, procurement, assembly, and packaging process.

In support of these efforts to provide environmentally-responsible products, please comply with the information in the following sections regarding product disposal for systems being replaced.

Disposal of your Electronic and Electric Equipment

Please do not dispose of electronic and electric equipment or electronic and electric accessories with your household waste. In some countries or regions, collection systems have been set up to handle waste of electrical and electronic equipment.

In European Union countries, please contact your local equipment supplier representative or service center for information about the waste collection system in your country.

Disposal Guideline

The following symbol on a Motorola product indicates that the product should not be disposed of with household waste.

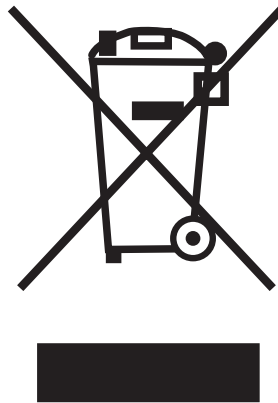

Part 68 Information

Part 68 FCC Guideline

This section applies when the MTR3000 Base Station/Repeater is equipped with the optional Wireline Interface Board.

This equipment complies with Part 68 of the FCC rules and the requirements adopted by the ACTA. On the rear of this equipment is a label that contains, among other information, the registration number:

US: ABZNINANT3000

If requested, this number must be provided to the telephone company.

The connector used to connect this equipment to the premises wiring and telephone network must comply with the applicable FCC Part 68 rules and requirements adopted by the ACTA. A compliant connector is provided with this product. See installation instructions for details.

REN: N/A

Connector: RJ1DC

Authorized Network Port: 04NO2

Service Order Code: 7.0Y

If the equipment causes harm to the telephone network, the telephone company will notify you in advance that temporary discontinuance of service may be required. But if advance notice is not practical, the telephone company will notify you as soon as possible. Also, you will be advised of your right to file a complaint with the FCC if you believe it is necessary.

The telephone company may make changes in its facilities, equipment, operations, or procedures that could affect the operation of the equipment. If this happens, the telephone company will provide advance notice in order for you to make necessary modifications to maintain uninterrupted service.

If you experience trouble with this equipment, please refer to "Appendix A", "Appendix C" or "Appendix D" for repair and warranty information. If the equipment is causing harm to the telephone network, the telephone company may request that you disconnect the equipment until the problem is resolved.

None of the circuit boards in this equipment are field repairable. For assistance in sending the boards back for repair, please contact the Service Center listed in "Appendix A", "Appendix C" or "Appendix D".

This equipment cannot be used on public coin phone service provided by the telephone company. Connection to party line service is subject to state tariffs. Contact the state public utility commission, public service commission or corporation commission for information.

Table of Contents

Foreword	i
General Safety Precautions.....	i
Manual Revisions	i
Parts Ordering	i
Computer Software Copyrights	i
Document Copyrights.....	i
Disclaimer.....	i
Trademarks	i
General Safety and Installation	
Standards and Guidelines	ii
MOTOTRBO MTR3000 Base Station/Repeater	
Supplemental Safety and Installation Requirements	iv
Environmental Information	v
Part 68 Information	vi
Chapter 1 Description	1-1
1.1 Introduction	1-1
1.1.1 Flexible Mechanical Design	1-1
1.1.2 Electrical Design.....	1-2
1.1.2.1 Transmitter Circuitry	1-2
1.1.2.2 Receiver Circuitry	1-2
1.1.2.3 Station Control Module	1-2
1.1.2.4 Wireline Circuitry	1-2
1.1.3 Summary of Operating Features	1-3
1.1.3.1 Standard Features.....	1-3
1.1.3.2 Optional Features	1-4
1.2 Base Station/Repeater Components	1-5
1.3 Functional Theory of Operation	1-7
1.3.1 Transmitter Circuitry Operation	1-7
1.3.1.1 Introduction.....	1-7
1.3.1.2 Exciter Module Operation	1-7
1.3.1.3 Power Amplifier Module Operation	1-7
1.3.2 Receiver Circuitry Operation	1-8
1.3.2.1 Introduction.....	1-8
1.3.2.2 Receiver Module Operation.....	1-8
1.3.3 Station Control Module Operation	1-9
1.3.3.1 Introduction.....	1-9
1.3.3.2 Station Control Module Operation	1-9

1.3.4	Wireline Module Operation	1-10
1.3.4.1	Introduction	1-10
1.3.4.2	Wireline Module Operation	1-10
1.3.5	Power Supply Module Operation	1-11

Chapter 2 Installation 2-1

2.1	Pre-Installation Considerations	2-1
2.1.1	Installation Overview.....	2-1
2.1.2	Environmental Conditions at Intended Installation Site	2-2
2.1.3	Equipment Ventilation.....	2-3
2.1.4	AC Input Power Requirements	2-4
2.1.5	DC Input Power Requirements	2-4
2.1.6	Equipment Mounting Methods	2-4
2.1.6.1	Floor-Mount Cabinet	2-5
2.1.6.2	Modular Racks.....	2-6
2.1.7	Site Grounding and Lightning Protection	2-7
2.1.7.1	Site Grounding Lightning Protection Recommendations	2-7
2.1.7.2	Equipment Grounding Guidelines	2-7
2.1.8	Recommended Tools and Equipment	2-8
2.1.9	Equipment Unpacking and Inspection	2-8
2.1.10	Base Station/Repeater Unpacking.....	2-8
2.2	Mechanical Installation.....	2-9
2.2.1	Unpacking Equipment.....	2-9
2.2.1.1	Introduction	2-9
2.2.1.2	Unpacking Base Stations/Repeaters	2-9
2.2.1.3	Front Bezel – Removal and Replacement	2-9
2.2.1.4	Unpacking Floor-Mount Cabinets	2-10
2.2.2	Mounting Procedures.....	2-12
2.2.2.1	Introduction	2-12
2.2.2.2	Installing Racks.....	2-12
2.2.2.3	Mounting Floor-Mount Cabinets	2-12
2.2.2.4	Transferring Equipment from Shipping Container to Rack or Cabinet.....	2-13
2.2.2.5	Installing Slide Rail Assembly in a Motorola Cabinet.....	2-13
2.2.2.6	Installing Slide Rail Assembly in a Non-Motorola Cabinet.....	2-15
2.3	Electrical Connections	2-17
2.3.1	Power Supply Connections.....	2-18
2.3.1.1	AC Input Power Connection	2-18
2.3.1.2	DC Input Power Connection	2-18
2.3.1.3	Ground Connection.....	2-19
2.3.1.4	Battery Connection	2-19
2.3.2	RF Antenna Connections.....	2-20
2.3.3	System Cable Connections	2-20
2.3.4	Base Station/Repeater Maintenance Connections	2-26
2.4	Post Installation Checklist	2-27
2.4.1	Applying Power.....	2-27
2.4.2	Verifying Proper Operation	2-27
2.4.2.1	Front Bezel LEDs.....	2-28
2.4.2.2	Exercising Radio Operation	2-30
2.5	Optimization	2-30
2.5.1	Optimizing Tasks	2-30
2.5.2	Copying Base Station/Repeater Codeplug Date To a PC-compatible Computer	2-31
2.6	Installing Base Station/Repeater Hardware Options.....	2-31

Chapter 3	Base Station/Repeater Operation	3-1
3.1	Description	3-1
3.1.1	LED Indicators	3-1
3.1.2	External Device Connections	3-1
3.1.3	Service Connections	3-2
Appendix A	EMEA Regional Warranty, Service and Technical Support	A-1
A.1	Warranty and Service Support	A-1
A.1.1	Warranty Period and Return Instructions	A-1
A.1.2	After Warranty Period	A-1
A.2	European Radio Support Centre (ERSC)	A-2
A.3	Piece Parts	A-2
A.4	Technical Support	A-3
A.5	Further Assistance From Motorola	A-3
Appendix B	Commercial Warranty	B-1
Appendix C	LACR Replacement Parts Ordering and Motorola Service Centers	C-1
C.1	Replacement Parts Ordering	C-1
C.1.1	Basic Ordering Information	C-1
C.1.2	Motorola Online	C-1
C.2	Motorola Service Centers	C-1
C.2.1	Servicing Information	C-1
C.2.2	Motorola de México, S.A.	C-1
C.2.3	Motorola de Colombia, Ltd.	C-1
Appendix D	NAG Replacement Parts Ordering and Motorola Service Centers	D-1
D.1	Replacement Parts Ordering	D-1
D.1.1	Basic Ordering Information	D-1
D.1.2	Motorola Online	D-1
D.1.3	Mail Orders	D-1
D.1.4	Telephone Orders	D-1
D.1.5	Fax Orders	D-2
D.1.6	Parts Identification	D-2
D.1.7	Product Customer Service	D-2
D.2	Motorola Service Centers	D-2
D.2.1	Servicing Information	D-2
D.2.2	Motorola Service Center	D-2
D.2.3	Motorola Federal Technical Center	D-2
D.2.4	Motorola Canadian Technical Logistics Center	D-2

**Appendix E MOTOTRBO Base Station/Repeater –
EME ASSESSMENT E-1**

- E.1 Executive SummaryE-1
- E.2 Exposure Prediction ModelE-1
 - E.2.1 Exposure in Front of the AntennaE-1
 - E.2.2 Exposure at Ground LevelE-3
- E.3 Typical System ConfigurationE-4
- E.4 Exposure LimitsE-4
- E.5 EME Exposure EvaluationE-4
 - E.5.1 Exposure in Front of the AntennaE-4
 - E.5.2 Exposure at Ground LevelE-4
- E.6 Compliance Boundary Description.....E-5
- E.7 References.....E-5

List of Figures

Figure 1-1	MTR3000 Base Station/Repeater	1-1
Figure 1-2	MTR3000 Base Station/Repeater Components	1-5
Figure 1-3	VHF and UHF Receiver Module Functional Block Diagram.....	1-13
Figure 1-4	800/900 MHz Receiver Module Functional Block Diagram.....	1-14
Figure 1-5	Exciter Module Functional Block Diagram	1-15
Figure 1-6	Power Amplifier Functional Block Diagram	1-16
Figure 1-7	Wireline Functional Block Diagram	1-17
Figure 2-1	Floor-Mount Cabinet	2-5
Figure 2-2	Modular Rack	2-6
Figure 2-3	Removal and Replacement of Front Bezel	2-9
Figure 2-4	Remove Cardboard Cover	2-10
Figure 2-5	Remove Antistatic Bag.....	2-11
Figure 2-6	Remove Bolts and Nuts	2-11
Figure 2-7	Slide Rail Installation for Motorola Cabinet (Left Side Shown).....	2-14
Figure 2-8	Slide Rail Installation for Non-Motorola Cabinet (Left Side Shown).....	2-16
Figure 2-9	ESD Connect	2-17
Figure 2-10	Location of External Connectors at Rear of Base Station/Repeater	2-17
Figure 2-11	Making Connections to Storage Battery.....	2-20
Figure 3-1	Front Bezel LEDs and Connectors.....	3-1
Figure 3-2	SCM Connectors.....	3-2
Figure E-1	Reference frame for the point of interest (POI) cylindrical co-ordinates	E-2
Figure E-2	Schematic of the ground-level exposure model adopted for the assessment.....	E-3
Figure E-3	Compliance boundary for general public (GP) and occupational (OCC) exposure.....	E-5

Notes

List of Tables

Table 1-1.	Power Supply Module AC Performance Specification	1-11
Table 1-2.	Power Supply Module DC Performance Specification	1-11
Table 2-1.	Cabinet Models	2-5
Table 2-2.	Cabinet Slides	2-5
Table 2-3.	Rack Models	2-6
Table 2-4.	Plugs for Different Countries	2-18
Table 2-5.	J7 Auxiliary System Connector Pins	2-21
Table 2-6.	J5 System Connector, Row A Pins	2-23
Table 2-7.	J5 System Connector, Row B Pins	2-24
Table 2-8.	J5 System Connector, Row C Pins	2-25
Table 2-9.	SCM Connectors.....	2-26
Table 2-10.	Front Bezel LED indicators	2-28
Table 2-11.	MTR3000 Software and Hardware Controlled LEDs	2-29

Related Publications

MOTOTRBO MTR3000 Base Station/Repeater Basic Service Manual.....	68007024096
MOTOTRBO MTR3000 Base Station/Repeater Detailed Service Manual	68007024097
Motorola Quality Standards Fixed Network Equipment Installation Manual R56.....	6881089E50

Chapter 1 Description

1.1 Introduction

The Motorola MTR3000 base station/repeater provides a modular, flexible analog and digital station designed for today's communication systems and of the future. The stations are available for use in these configurations:

- Analog Conventional
- Digital (MOTOTRBO)
 - MOTOTRBO DMR Tier 2 Conventional – Single Site
 - MOTOTRBO DMR Tier 2 Conventional – IP Site Connect
 - MOTOTRBO Capacity Plus Trunking
 - MOTOTRBO Connect Plus Trunking
 - MOTOTRBO Transmit Interrupt
 - MOTOTRBO Dynamic Mixed Mode (DMM)
- LTR Trunking
- Passport Trunking

NOTE: At any given time, the base station/repeater either operates as a digital repeater or as an analog repeater.

Refer to the Summary of Operating Features section for a list of standard features and optional features.

1.1.1 Flexible Mechanical Design

All elements of the base station/repeater are designed for EIA 48.3 cm (19") rack mounting, allowing the equipment to be mounted in standard telephone-style equipment racks, or various sizes of Motorola cabinets. Figure 1-1 shows a typical base station/repeater.



Figure 1-1 MTR3000 Base Station/Repeater

1.1.2 Electrical Design

1.1.2.1 Transmitter Circuitry

The base station/repeater transmitter circuitry is designed for continuous duty operation and may be operated at full rated power. Output power is continually monitored by an internal directional coupler. The forward power voltage from the coupler feeds a power control loop which continually adjusts and maintains the desired output power. All adjustments are electronic, including deviation and output power.

1.1.2.2 Receiver Circuitry

The base station/repeater receiver circuitry features multiple bandwidth (12.5 kHz, 20 kHz, 25 kHz, and 30 kHz) capability. Injection signals for the first and second mixers are generated by frequency synthesizer circuitry electronically controlled by the Station Control Module (SCM). All receive signals (analog) are detected and digitized before being sent to the SCM, providing improved, consistent audio quality throughout the coverage area.

NOTE: For UHF band, 30 kHz bandwidth is not supported.

For digital mode, only 12.5 kHz bandwidth is supported.

1.1.2.3 Station Control Module

The SCM is microprocessor-based and features extensive use of ASIC and digital signal-processing technology. The SCM serves as the main component for the base station/repeater, providing signal-processing and operational control for the base station/repeater modules.

1.1.2.4 Wireline Circuitry

The station wireline circuitry options provide a wide variety of telephone interfaces and remote control mechanisms such as Tone Remote Control and DC Remote Control. Telephone line connections are easily made to the wireline circuitry via connectors on the rear of the station.

1.1.3 Summary of Operating Features

1.1.3.1 Standard Features

The following are the standard features for the base station/repeater:

- MOTOTRBO Conventional Operation (2-Slot TDMA, 4FSK Modulation)
- Analog Conventional Operation (FM)
- Continuous Duty Cycle Operation over -30°C to +60°C
- Meets or exceeds the following standards:
 - TIA603D
 - ETSI 086
 - ETSI 113
 - ETSI TS 102 361-1 Part 1: DMR Air Interface Protocol
 - ETSI TS 102 361-2 Part 2: DMR Voice and Generic Services and Facilities
 - ETSI TS 102 361-3 Part 3: DMR Packet Data Protocol
- Synthesized Frequency Generation
- Two Female N-type Antenna Connectors (Rx and Tx)
- Ethernet Port (Network)
- Front mounted USB Port (Service)
- Front mounted microphone port
- Front mounted speaker port
- 9 configurable GPIO/GPI ports
- Power for third party controllers (1 AMP)
- 1.5 PPM Frequency Stability (Temperature AND 1-Year Aging) (VHF and UHF)
- 0.1 PPM Frequency Stability (Temperature AND 1-Year Aging) (800/900 MHz)
- External Reference Capability
- Wireline Capability
- Switching Power Supply operates from 85–264 VAC and frequencies of 47–63 Hz
- Multi-Power Source configurable (AC, DC, or AC with Battery Revert)
- Station Diagnostic Tests-Fixed Set of Tests Factory run upon Start-up
- Physical Dimensions: 5.25" H x 19" W x 16.5" D (133 x 483 x 419 mm) 3RU
- Weight: 40 pounds (19kg) excluding a cabinet or other peripheral equipment

Motorola Network Interface for:

- IP Site Connect
- Repeater Diagnostics and Control (RDAC)

Third Party Controller Interface:

- Phone Patch
- Multi Coded Squelch Interface (Repeater Panel)
- Tone Remote Adapter
- LTR Trunking
- Passport Trunking

NOTE: The MTR3000 base station/repeater only supports the third party controllers noted above when it is configured in analog mode.

1.1.3.2 Optional Features

The following are the optional features for the base station/repeater:

- External Pre-selector (Not available for the 800/900 MHz band)
- Antenna Relay
- Duplexer (Not available for the 900 MHz band)
- External Dual Circulator Tray (Not available for the 900 MHz band)
- Integrated Tone Remote Control (with Wireline option)
- Integrated DC Remote Control (with Wireline option)
- Analog Voting (with Wireline option)

In addition, the following features are also included. These features are shipped in a preset condition, but may be altered through the use of the CPS.

- 16 Tx/Rx Frequencies – Factory Programmed with 1 Tx, 1 Rx
- 12.5 kHz or 25 kHz Operation – Factory Programmed to 12.5 kHz
- 6.25e compliant
- 1 Tx and 1 Rx (PL or DPL) Squelch Code per channel – Factory Programmed to CSQ
- Base Station Identification (BSI) – Factory Programmed as “BLANK” (“BLANK” disables BSI)
- Push-To-Talk (PTT) Priority – Factory Programmed to Repeat Path

1.2 Base Station/Repeater Components

Figure 1-2 shows the modules and components that comprise a base station/repeater.

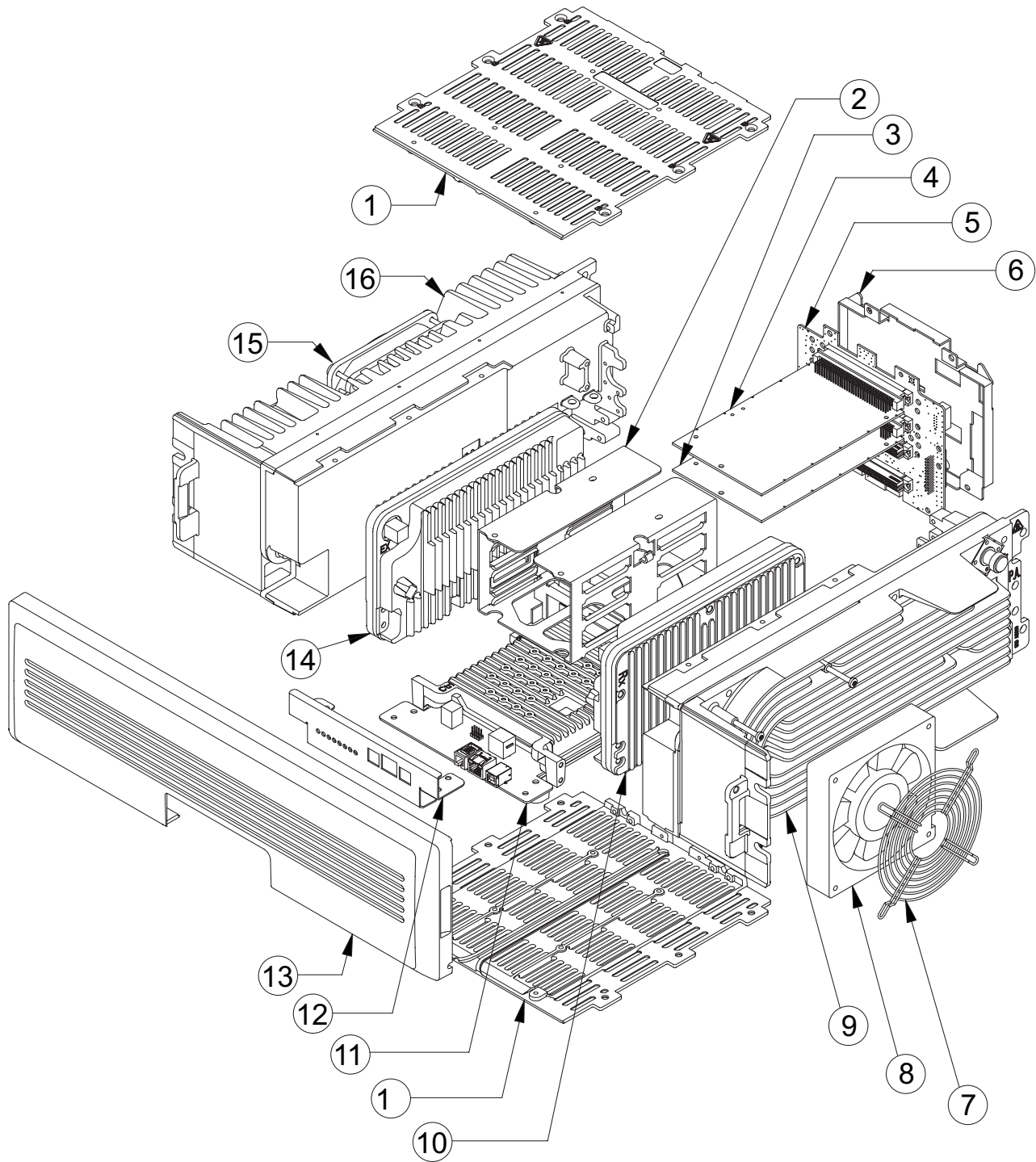

Figure 1-2 MTR3000 Base Station/Repeater Components

Item No.	Description
1	Top/Bottom Chassis Plate
2	Option Card Bracket
3	Auxiliary I/O Board (FRU) ^a
4	4-wire Wireline Board
5	Backplane Interface Board
6	Backplane Interface Board Shield
7	Fan Grille (Power Amplifier or Power Supply)
8	Power Amplifier Fan
9	Power Amplifier (FRU)
10	Receiver Module (FRU)
11	Station Control Module (FRU)
12	Station Control Module Front Panel
13	Front Bezel
14	Exciter Module (FRU)
15	Power Supply Fan
16	Power Supply (FRU)

a. Auxiliary I/O Board is not available.

1.3 Functional Theory of Operation

The following functional theory of operation provides an overview of the base station/repeater circuitry.

1.3.1 Transmitter Circuitry Operation

1.3.1.1 Introduction

The Transmitter Circuitry comprises two modules, the Exciter Module and the Power Amplifier (PA) Module. These modules combine to generate, modulate, and amplify the RF signal which is transmitted via the site transmit antenna.

1.3.1.2 Exciter Module Operation

The Exciter Module, which interfaces directly to the SCM, generates a modulated RF signal at the desired transmit frequency and sends this signal to the PA for amplification. The circuitry operates as follows.

The transmit synthesizer and Voltage-Controlled Oscillator (VCO) circuitry on the Exciter Module accept frequency programming data from the SCM via the Serial Peripheral Interface (SPI) bus, and generate an RF carrier at the specified frequency. The VCO is directly modulated by transmit audio/data from the SCM. The resulting modulated RF signal (at a level of approximately +12 dBm) is then fed to the PA.

See Figure 1-5 for the Exciter block diagram.

1.3.1.3 Power Amplifier Module Operation

The PA modules are designed for continuous-duty operation across all bands and power levels. The actual circuit stages employed in a PA depend on the specific frequency band. All PA modules contain a driver and final RF amplification stage, a low-pass filter/directional coupler at the output, and diagnostic and power control circuitry.

The PA modules employ a single internal circulator to protect the PA from transmitter intermodulation and antenna mismatch (VSWR). They are broadband devices and require no tuning to operate at the base station/repeater site.

The modulated RF signal from the Exciter Module is delivered to the PA Module and amplified to the specified output power via the driver and final amplification stages. The gain of the driver stage is controlled by a control voltage which is derived from power control signals from the SCM and high VSWR/thermal protection circuitry on the PA output board.

A combination of hardware and software controls are used to regulate the power output level. To set the power and current limits, the SCM provides software control through a D/A converter connected to the SPI bus. This control relies on various monitored PA signals which are fed back to the SCM via an A/D converter (also connected to the SPI bus).

The directional coupler is essentially a calibrated wattmeter which feeds a DC voltage proportional to the output power to the power control circuitry to serve as the feedback signal in the power control loop. Under normal operating conditions, the power control circuitry compares this DC voltage from the directional coupler to a reference voltage from the D/A converter which represents the desired output power. Based on the comparison, a power control voltage is generated to control the output power from the PA Module.

The modulated RF signal is amplified by the Driver/Final Module and is output to the site transmit antenna via a circulator and a harmonic filter/coupler. During excessive output VSWR, the ratio of the forward and reflected voltages from the directional coupler may be used to reduce, or turn off, the transmitter power. Additional circuitry is also provided to reduce output power during excessive current drain and high temperature conditions, and to control the fan.

See Figure 1-6 for the Power Amplifier block diagram.

1.3.2 Receiver Circuitry Operation

1.3.2.1 Introduction

The Receiver Circuitry accepts receive RF signals from the site receive antenna, performs filtering and dual conversion, and outputs a digitized receive signal to the SCM. The receiver module utilized has an on-board preselector.

1.3.2.2 Receiver Module Operation

The receive signal is input from the site receive antenna to the receiver module, or to an external preselector filter (a separate assembly attached to the rear of the base station/repeater which provides highly selective bandpass filtering). The signal is fed through a low-pass filter, varactor-tuned preselector (VHF/UHF)/fixed preselector (800/900 MHz), RF amplifier and image filter to the RF input of the first mixer. The filtered signal is mixed with an injection signal generated by the receive synthesizer/VCO, resulting in a first i-f (intermediate frequency) signal. The injection signal frequency is determined by frequency programming data from the SCM via the SPI bus. The specific frequency of the first i-f depends on the frequency band of the base station/repeater.

The first i-f signal is filtered and input to a custom receiver IC. This component contains circuitry for generating the second injection signal, mixing down the first i-f to 2.25 MHz, amplification and A/D (analog-to-digital) conversion of the second i-f signal, resulting in a digitized receive signal. This signal is fed as differential data to the SCM.

See Figure 1-3 for the Receiver block diagram.

1.3.3 Station Control Module Operation

1.3.3.1 Introduction

The heart of the SCM Module is the two Texas Instruments OMAP1710 processors. Each OMAP processor contains an ARM Host and a C55 DSP processor. One of these OMAP processor is dedicated to Receiver DSP operations, while the other OMAP provides for all other operations, including the transmitter functions.

1.3.3.2 Station Control Module Operation

The SCM controls the entire coordination of the base station/repeater functions. Specifically, the SCM provides for the following functionalities:

- Contains and runs the preloaded base station/repeater software
- Manages inbound and outbound RF and Audio traffic
- Provides external speaker and microphone ports
- Provides an on-board USB port for local configuring, alignment and diagnostics via the following applications:
 - Customer Programming Software (CPS)
 - Tuner application
 - Repeater Diagnostic and Control (RDAC) software
 - Online Help
- Provides an Ethernet port for IP site, Capacity Plus, Connect Plus, connectivity and remote RDAC
- Provides GPIO connectivity for third party controller interfaces
- Provides for analog base station/repeater audio connectivity
- Data and Control to the Receiver via the SPI and SSI respectively
- Data and Control to the Exciter via the SPI and SSI respectively
- Control of the PA's set power via the SPI
- Generates the internal station reference
- Provides control of the front panel status indicators

1.3.4 Wireline Module Operation

1.3.4.1 Introduction

The wireline module serves as the interface between the analog telephone lines and the analog signals of the station. The wireline module supports both 2-wire and 4-wire configurations. In general, the wireline processes and routes all wireline audio signals between the station and the landline equipment (such as consoles). Landline-to-station and station-to-landline audio signals are connected to the wireline via copper pairs at the rear of the station.

1.3.4.2 Wireline Module Operation

Wireline board is used to connect an analog audio source and sink (such as a console) to the base station/repeater. The wireline uses an on-board FPGA to perform various DSP audio processing functions such as tone remote control, filtering, wireline squelch, and echo cancellation.

On the wireline board, audio is converted from the analog domain to the digital domain by a CODEC. The FPGA can then process the digital audio before sending the data back to the CODEC to be converted back to analog. Both the Tx and Rx path are processed by the FPGA in this way. Audio enters and leaves the wireline board as analog.

Rx Audio represents data received over-the-air by the base station/repeater's receiver module. Tx Audio is analog audio that originates from a remote location that is to be broadcast over-the-air by the station's transmitter. A single 2-channel (stereo) CODEC is used to perform the A/D and D/A conversions.

The wireline board provides the connection to an analog audio source/sink (such as a console) to the MTR3000 Base Station/Repeater. Specifically, the wireline board provides for the following:

- Tone Remote Control
- DC Remote Control
- Analog Voting
- 4-wire balanced audio connection
- 2-wire balanced audio connection

See Figure 1-7 for the Wireline block diagram.

1.3.5 Power Supply Module Operation

Power Supply Modules are offered to handle:

- AC or DC input power
- Base station/repeater requirements

A Power Supply Module is used in a base station/repeater with a Power Amplifier Module (e.g. rated at 100 W output power).

- **AC Input Power**

The model generates the +5.1 V, +14.2 V, and +28.6 V operating voltages for the base station/repeater modules.

These modules have power factor correction and include a connection for battery backup.

Table 1-1. Power Supply Module AC Performance Specification

Input Voltage Range	Output Voltages	Power Factor Correction
85 to 264 VAC	+5.1 V, +14.2 V, and +28.6 V	Provided internally within power supply module.

- **DC Input Power**

The model accepts a DC input (+21.7 to +32 VDC). The output voltages are:

- the input filtered voltage
- a regulated +5.1 VDC
- a regulated +14.2 VDC.

Table 1-2. Power Supply Module DC Performance Specification

Input Voltage Range	Output Voltages
21.6 to 32 VDC	+5.1 V, +14.2 V, and +28.6 V

Notes

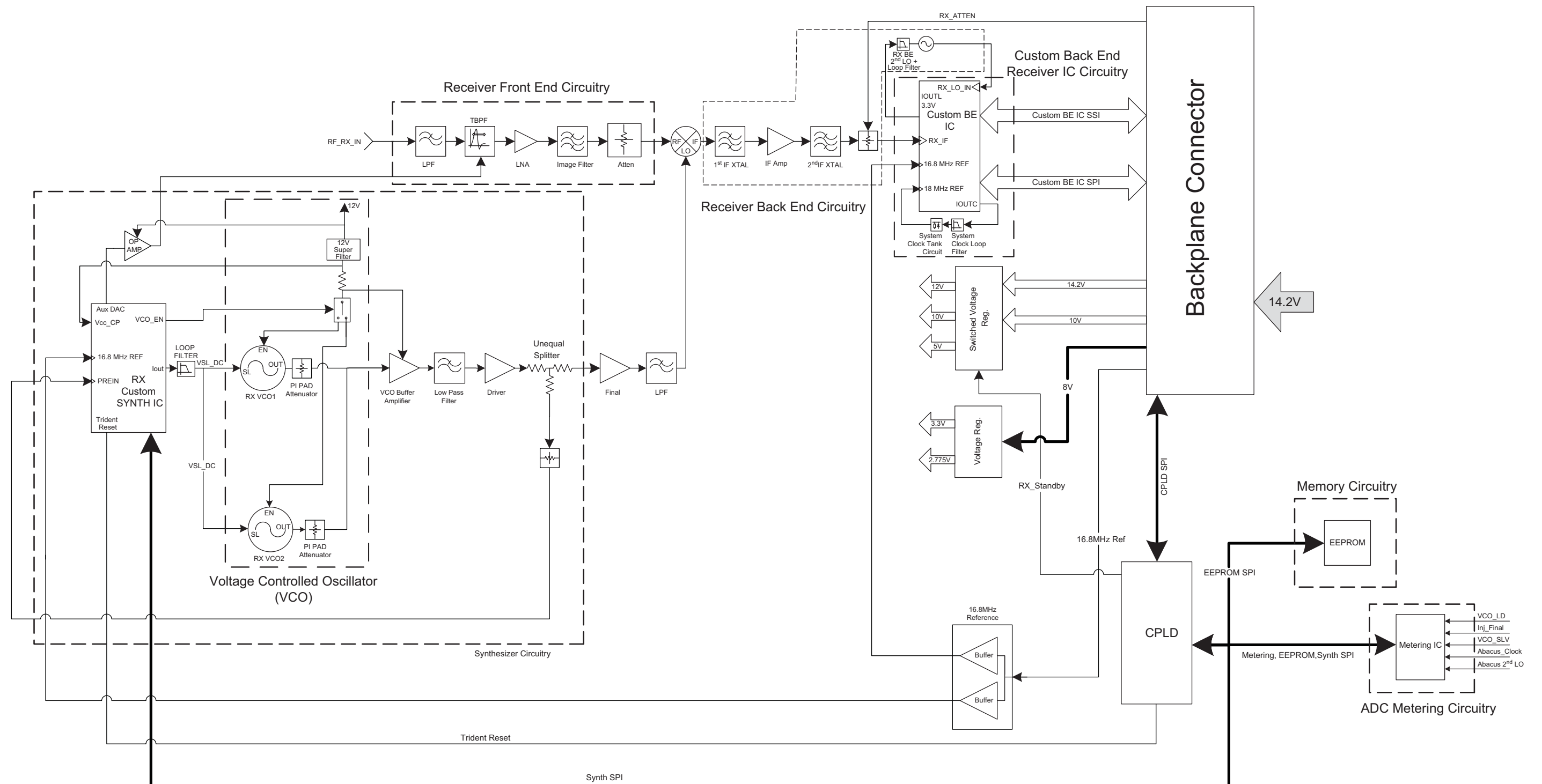

Figure 1-3 VHF and UHF Receiver Module Functional Block Diagram

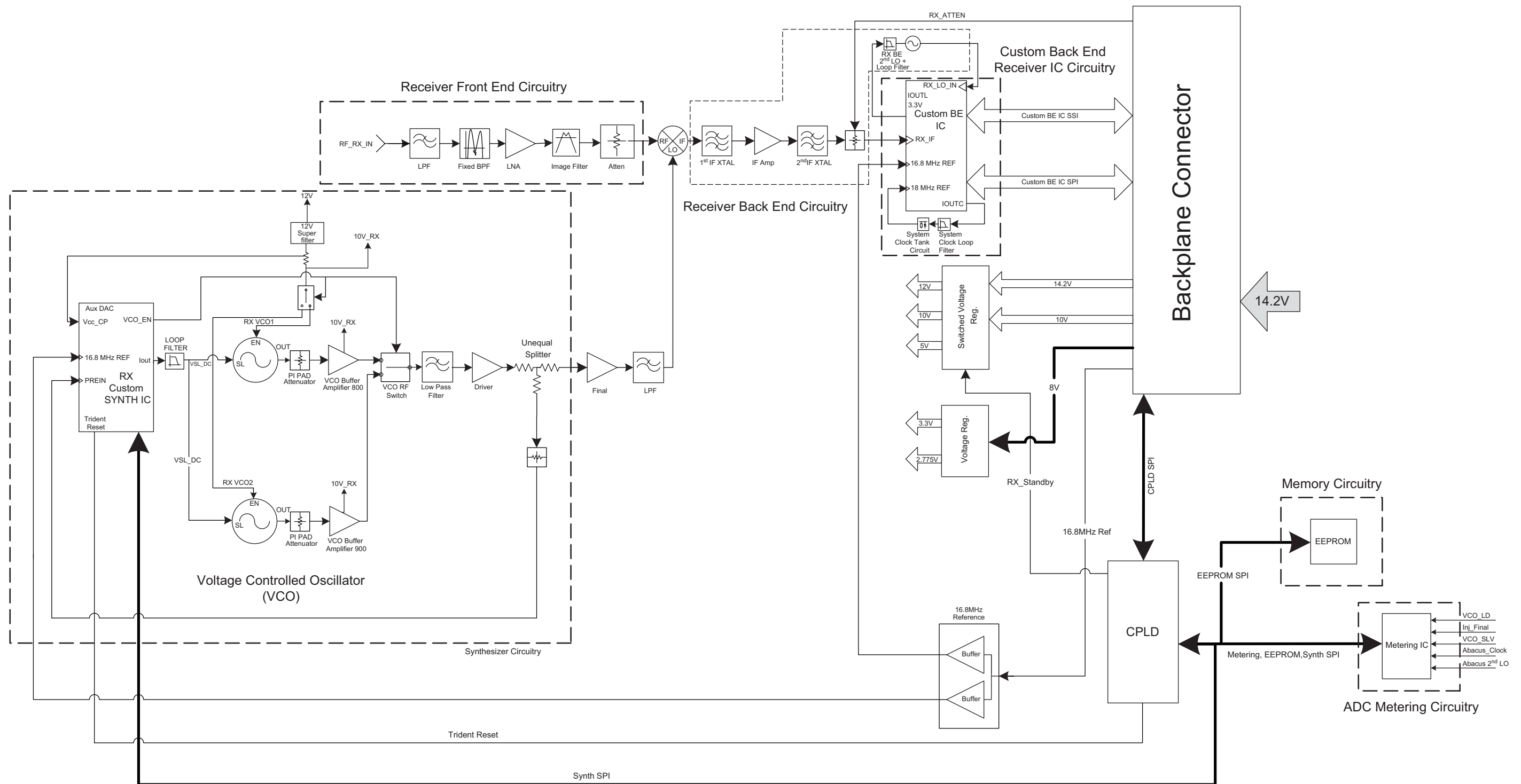

Figure 1-4 800/900 MHz Receiver Module Functional Block Diagram

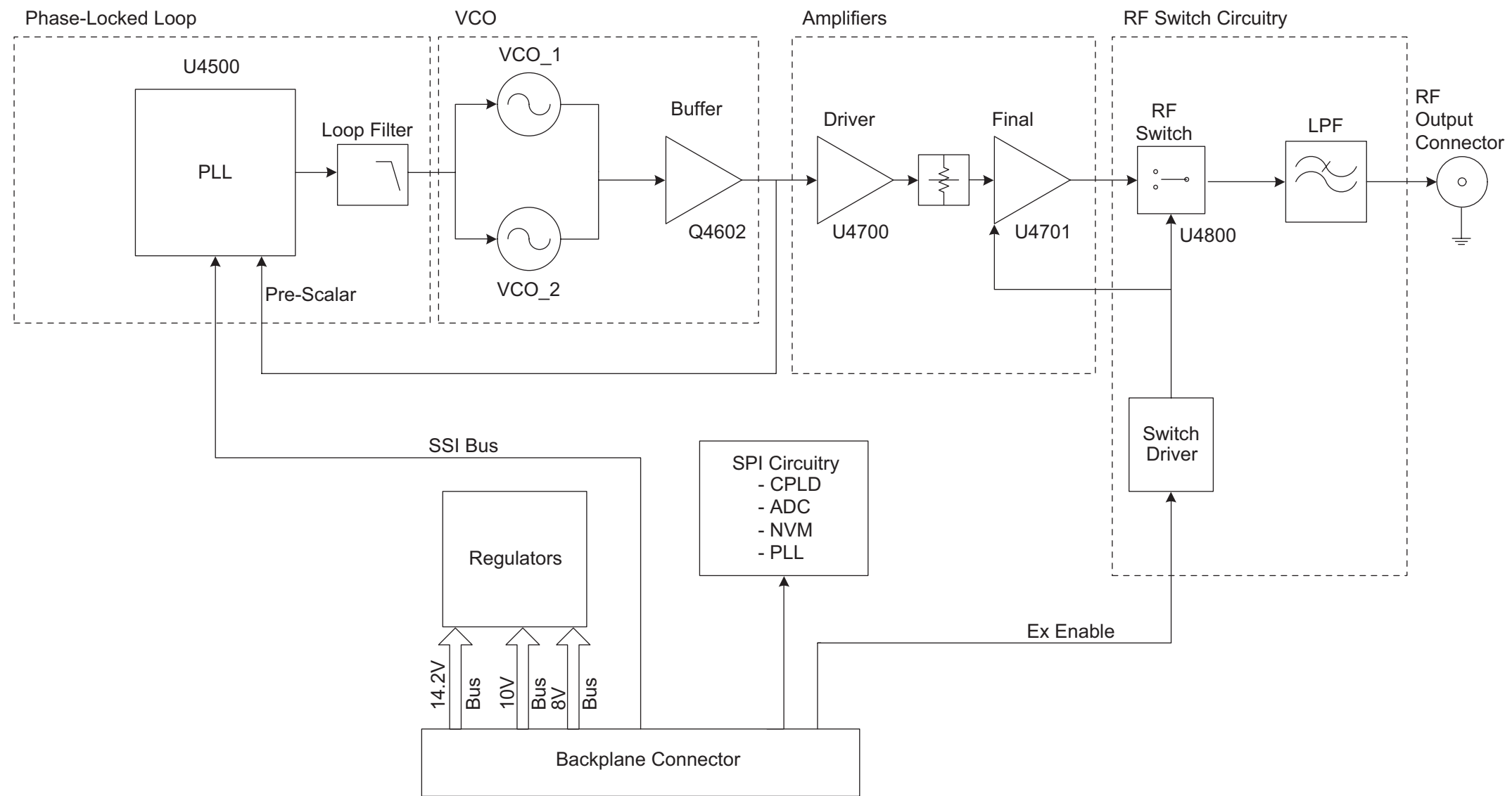

Figure 1-5 Exciter Module Functional Block Diagram

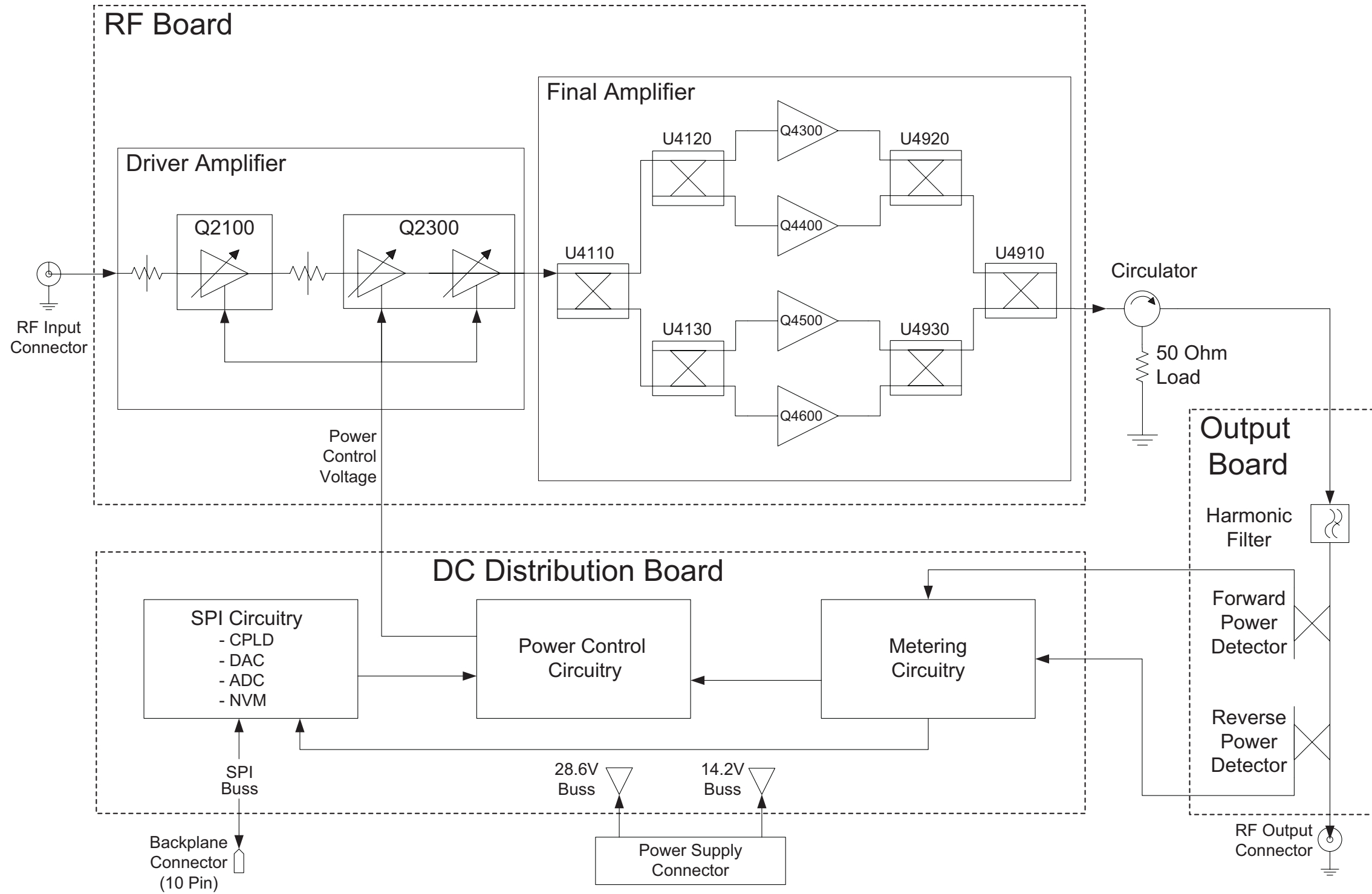

Figure 1-6 Power Amplifier Functional Block Diagram

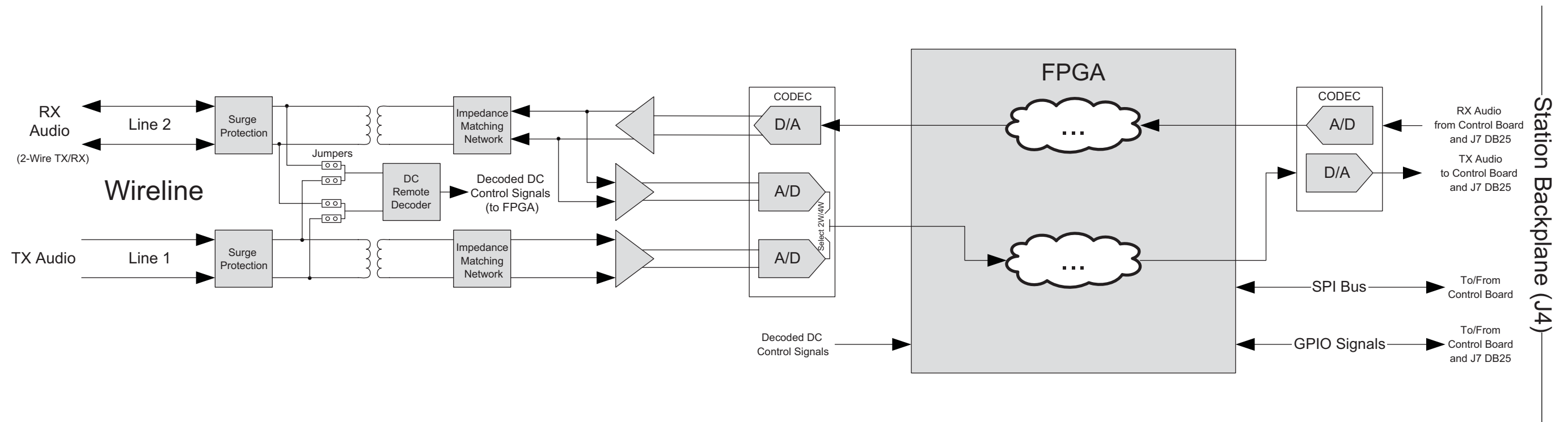

Figure 1-7 Wireline Functional Block Diagram

Notes

Chapter 2 Installation

2.1 Pre-Installation Considerations

Proper installation ensures the best possible performance and reliability of the base station/repeater equipment. Pre-installation planning is required. This includes considering the mounting location of the equipment in relation to input power, antennas, and telephone interfaces. Also to be considered are site environment conditions, the particular mounting method (several available), and required tools and equipment.

If this is the first time installing this type of equipment, it is highly recommended that the user read:

- this entire installation section before beginning the actual installation, and
- the Motorola Quality Standards Fixed Network Equipment Installation manual, R56 (6881089E50); specifically refer to the information on ground connection for lightning protection.

2.1.1 Installation Overview

The following information is an overview for installing the base station/repeater and ancillary equipment. Step-by-step procedures for each of the major installation tasks are then provided beginning in "Mechanical Installation" section on page 2-9.

- Plan the installation, paying particular attention to environmental conditions at the site, ventilation requirements, and grounding and lightning protection.
- Unpack and inspect the equipment.
- Mechanically install the equipment at the site.
- Make necessary electrical and cabling connections, including the following:
 - AC input cabling
 - Coaxial cables to transmit and receive antennas
 - Phone line connections
 - System cables
- Perform a post-installation functional checkout test of the equipment to verify proper installation.
- Proceed to the Optimization procedures to customize the base station/repeater parameters per customer specifications (e.g., operating frequency, PL, codes, etc.).

2.1.2 Environmental Conditions at Intended Installation Site

IMPORTANT: If the base station/repeater is to be installed in an environment which is unusually dusty or dirty (and so does not meet the air quality requirements), the air used to cool the base station/repeater modules must be treated using appropriate filtering devices. Dust or dirt accumulating on the internal circuit boards and modules is not easily removed, and can cause such malfunctions as overheating and intermittent electrical connections.

The base station/repeater may be installed in a suitable, restricted access, indoor enclosure in any location suitable for electronic communications equipment, provided that the environmental conditions do not exceed the equipment specifications for temperature, humidity, and air quality. These are:

- Operating Temperature Range

-30°C (-22°F) to +60°C (+140°F)

This is the temperature measured in close proximity to the base station/repeater. For example, if the base station/repeater is mounted in a cabinet, the temperature within the cabinet would be measured.

- Humidity

Not to exceed 95% relative humidity @ 50°C (122°F).

- Air Quality

For equipment operating in an environmentally controlled environment with the base station(s)/repeater(s) rack mounted, the airborne particulates level must not exceed 25 µg/m³.

For equipment operating in an area which is not environmentally controlled (base station(s)/repeater(s) cabinet mounted), the airborne particulates level must not exceed 90 µg/m³.

2.1.3 Equipment Ventilation

The base stations/repeaters are equipped with cooling fans that are used to provide forced convection cooling.

When planning the installation, observe the following ventilation guidelines.

- Mounting the MTR3000 base station/repeater in a cabinet
 - Cabinets must be equipped with ventilation slots or openings in the front (for air entry) and back or side panels (for air to exit). If several base stations/repeaters are installed in a single cabinet, be sure ventilation openings surround each base station/repeater to allow for adequate cooling.
 - All cabinets must have at least 15 cm (6 in) of open space between the air vents and any wall or other cabinets. This allows adequate air flow.
 - When multiple cabinets (each equipped with several base stations/repeaters) are installed in an enclosed area, make sure the temperature within each cabinet does not exceed the recommended/maximum operating temperature of +60°C (+140°F). It may be necessary to have air-conditioning or other climate-control equipment installed to satisfy the environmental requirements.

IMPORTANT: The mounting of only ONE BASE STATION/REPEATER PER CABINET is recommended. More than one base station/repeater per cabinet will result in degradation of thermal specifications at high ambient temperatures.

Appropriate precautions should be taken to ensure that base station/repeater ambient temperature does not exceed +60°C (+140°F).

If multiple base stations/repeaters are required, AND THERMAL SPECIFICATION DEGRADATION IS ACCEPTABLE, the following is recommended when no cabinet fans are used. Up to three base stations/repeaters can be mounted in a 76.2 cm (30 in) or larger cabinet with two rack units of spacing between each base station/repeater. This will result in thermal specification performance of -30°C (-22°F) to +40°C (+104°F).

- Mounting the MTR3000 base station/repeater in a Rack

 <p>Caution</p>	<p>Multiple MTR3000 base stations/repeaters can be mounted in an open rack without degradation of specification. To maintain thermal specifications for equipment including the X621BF option, MTR3000 base stations/repeaters require one rack unit of spacing between base stations/repeaters. For base stations/repeaters with the X621BF option installed, with no spacing, the base stations/repeaters' ambient temperature may not exceed +55°C (+131°F).</p>
--	---

2.1.4 AC Input Power Requirements

The base station/repeater is equipped with a switching power supply, this assembly operates from 85 VAC to 264 VAC at 47 to 63 Hz AC input power. A standard 3-prong line cord is supplied to connect the power supply to the AC source.

It is recommended that a standard 3-wire grounded electrical outlet be used as the AC source.

 Caution	The AC socket-outlet must be installed near the equipment and must be easily accessible.
--	--

The outlet must be connected to an AC source capable of supplying a maximum of 1020 VAC. For a nominal 110/120 VAC input, the AC source must supply 8.5 A and should be protected by a circuit breaker rated at 15 A. For a nominal 220/240 VAC input, the AC source must supply 4.25 A and should be protected by a circuit breaker rated at 10 A.

- **Requirement for European Union (EU) Countries**

Beginning January 1, 2001, input harmonic current specifications were changed for most electronic telecommunication equipment installed in EU countries. Accordingly, power factor correction is necessary for MTR3000 base stations/repeaters.

Power Supply model DLN6707 has internal power factor correction.

2.1.5 DC Input Power Requirements

The DC source operates from 21.6 VDC to 32 VDC. This DC source must be located in the same building as the base station/repeater, and it must meet the requirements of a SELV circuit.

The Power Supply module in the base station/repeater provides DC power to the Receiver, Exciter, SCM and Power Amplifier module via one or more of the three DC output taps; 28.6 VDC, 14.2 VDC and 5.1 VDC by using a DC Input cable.

2.1.6 Equipment Mounting Methods

The base station/repeater equipment can be mounted in a rack or cabinet.

The base station/repeater can be mounted:

- in a floor-mount indoor cabinet. Each floor-mount cabinet has front and rear vented doors and has the capacity to hold a minimum of a single base station/repeater (see thermal limitations described under Equipment Ventilation), and required ancillary equipment. The larger cabinets provide additional room for supplementary peripheral equipment.
- in a rack. Open frame racks accept multiple base stations/repeaters and ancillary equipment; EIA 48.3 cm (19 in) rack configuration.

2.1.6.1 Floor-Mount Cabinet

The front, side and top views for all available floor-mount cabinets are shown in Figure 2-1. See Table 2-1 for the cabinet models and associated description.

Table 2-1. Cabinet Models

Model	Description
THN6700	12 inch indoor cabinet
THN6701	30 inch indoor cabinet
THN6702	46 inch indoor cabinet

Refer to Section 2.1.3. Equipment Ventilation for recommended ventilation clearances.

For improved access to the unit, tray slides are available as shown in Table 2-2.

Table 2-2. Cabinet Slides

Model	Description
THN6788	Slides Motorola Cabinet
CLN6833	Slides Non-Motorola Cabinet



WARNING

Ensure that the cabinet is securely anchored to the floor, thereby avoiding possible equipment tipping and personal injury. Refer to Mounting Floor-Mount Cabinets for details on proper cabinet installation.

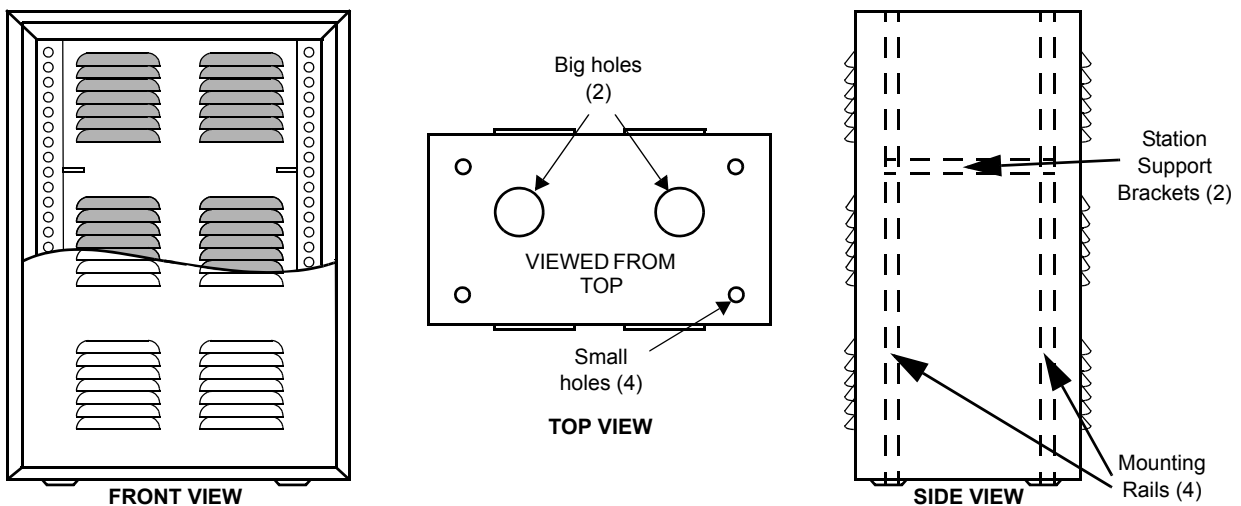

Figure 2-1 Floor-Mount Cabinet

2.1.6.2 Modular Racks

See Table 2-3 for the rack models and associated description.

Table 2-3. Rack Models

Model	Description
THN6752	30 inch Modular Rack (16 RK U)
THN6753	45 inch Modular Rack (24 RK U)
THN6754	52 inch Modular Rack (27 RK U)

The side, top and bottom views for all available modular racks are shown in Figure 2-2. The top and bottom plates are identical, and all dimensions and clearances are common to all racks.

Recommended clearance front and rear is 91.44 cm (36 in) minimum for servicing access. Refer to Equipment Ventilation for recommended ventilation clearances.

FRU kit CLN6679 (Rack Mount Hardware) is included with each rack model. This allows proper installation of the MTR3000 base station/repeater within the rack's center of gravity.

NOTE: This kit includes two rack mount standoffs and eight mounting screws.

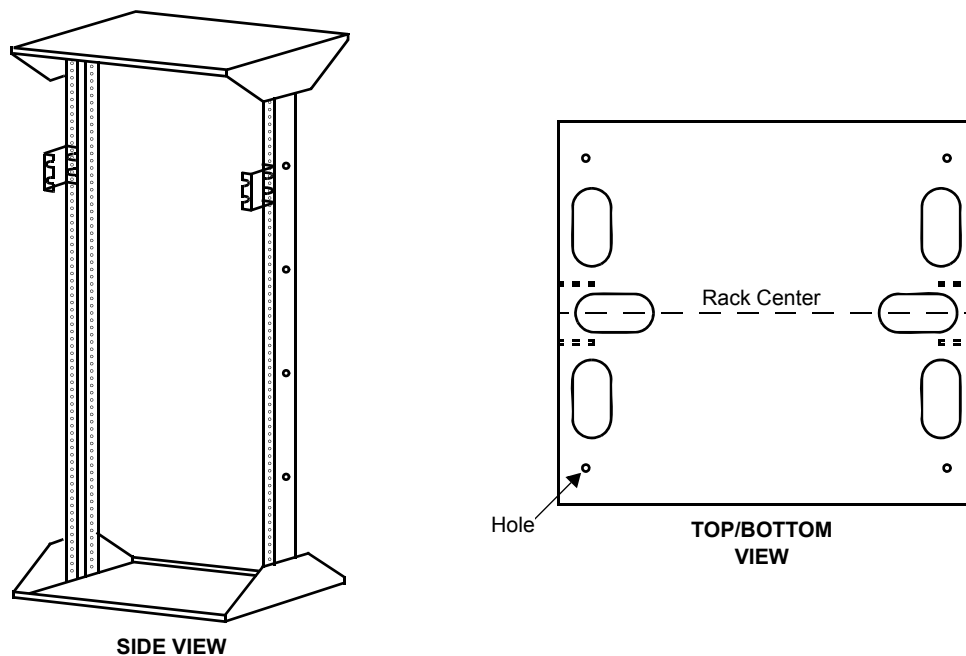

Figure 2-2 Modular Rack

2.1.7 Site Grounding and Lightning Protection

2.1.7.1 Site Grounding Lightning Protection Recommendations

IMPORTANT: Proper site grounding and lightning protection are vitally important considerations. Failure to provide proper lightning protection may result in permanent damage to the radio equipment.

One of the most important considerations when designing a communications site is the ground and lightning protection system. While proper grounding techniques and lightning protection are closely related, the general category of site grounding may be divided as follows:

- Electrical Ground

Ground wires carrying electrical current from circuitry or equipment at the site is included in the category of electrical ground. Examples include the AC or DC electrical power used to source equipment located at the site, telephone lines, and wires or cables connected to alarms or sensors located at the site.

- RF Ground

This type of ground is related to the transmission of radio frequency energy to earth ground. An example of RF grounding is the use of shielding to prevent or at least minimize the leakage of unwanted RF transmissions from communications equipment and cables.

- Lightning Ground

Providing adequate lightning protection is critical to a safe and reliable communications site. Telephone lines, RF transmission cables, and AC and DC power lines must all be protected to prevent lightning energy from entering the site building.

Although a comprehensive coverage of site grounding techniques and lightning protection is not within the scope of this manual, there are several excellent industry sources for rules and guidelines on ground and lightning protection at communications sites.

NOTE: Motorola recommends the following reference source:

Motorola Quality Standards Fixed Network Equipment Installation manual, R56
(6881089E50)

2.1.7.2 Equipment Grounding Guidelines

The base station/repeater is equipped with a ground screw located on the rear of the base station/repeater Power Supply module. This screw is used to connect the base station/repeater to the site ground point. It is assumed that all telephone lines, antenna cables, and AC or DC power cabling has been properly grounded and lightning protected by following the rules and guidelines provided in the above reference.

2.1.8 Recommended Tools and Equipment

In addition to the typical compliment of hand tools, the following tools and equipment are recommended for proper installation of the base station/repeater equipment.

- Tarpaulin or plastic drop cloth or cover surrounding equipment while drilling concrete anchor holes (for installations where cabinet or rack is being anchored to concrete).
- Vacuum cleaner for removing concrete dust caused by drilling.

2.1.9 Equipment Unpacking and Inspection

The base station/repeater equipment may be shipped by either air freight or electronic van (as specified by customer), except where noted. The base station/repeater is shipped in a box; the base station/repeater is positioned between pieces of cushioned corrugated cardboard.

Thoroughly inspect the equipment as soon as possible after delivery. If any part of the equipment has been damaged in transit, immediately report the extent of the damage to the transportation company and to Motorola.

NOTE: Antistatic plastic bags should be kept for future shipping/transporting of base station/repeater.

2.1.10 Base Station/Repeater Unpacking

When a base station/repeater is delivered from Motorola, it arrives in suitable packing materials. If the unpacked equipment is damaged, return it to Motorola in its original packaging.

 <p>WARNING</p>	<p>Equipment should be handled in its original packaging until it is delivered to its final destination. If the equipment is damaged while being moved without the original packaging, the warranty claim is not valid.</p>
--	--

2.2 Mechanical Installation

This section describes the procedures to unpack and mechanically install the base station/repeater equipment. A variety of mounting methods are possible, depending on whether a cabinet or rack (if any) has been selected to house the base station(s)/repeater(s). Installation procedures are provided for each of the cabinet and rack types, as well as the slide rail.

IMPORTANT: Be sure to observe proper electrostatic discharge precautions if modules must be removed from the base station/repeater.

2.2.1 Unpacking Equipment

2.2.1.1 Introduction

Base station/repeater equipment packing methods vary depending upon the type of rack or cabinet selected by the customer. Unpacking procedures for these various methods are provided in the following paragraphs.

IMPORTANT: The equipment must be immediately inspected for damage after unpacking, and a report of the extent of any damage made to the transportation company and to Motorola.

2.2.1.2 Unpacking Base Stations/Repeaters

The base station/repeater is shipped in a carton, cushioned by four plastic inserts at the corners of the carton.

 <p>WARNING</p>	<p>Improper handling of the base station/repeater may cause personal injury or damage to the base station/repeater. DO NOT pick up the base station/repeater by holding the Preselector (if so equipped). Use the handles on the front of the base station/repeater, or the Power Supply and Power Amplifier casings when picking up the base station/repeater.</p>
--	--

2.2.1.3 Front Bezel – Removal and Replacement

Remove the station front bezel from its chassis locking clip by carefully pulling it forward.

Replace the station front bezel by inserting one of the front bezel locking clips into corresponding latch on the station housing, and carefully pressing the panel on the opposite side until the second locking clip snaps into place.

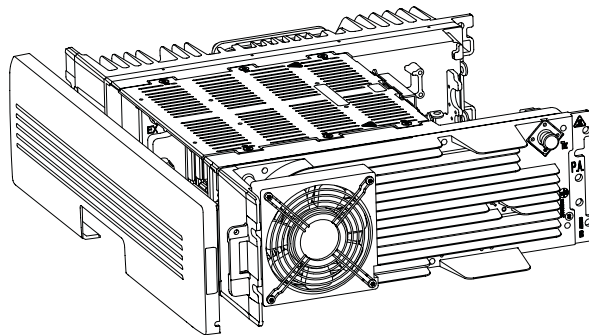

Figure 2-3 Removal and Replacement of Front Bezel

2.2.1.4 Unpacking Floor-Mount Cabinets

The floor-mount cabinets are shipped mounted to a wooden skid, secured with corrugated corner braces held by a plastic strap, and covered with a cardboard cover. Unpack the equipment as described below.

1. Remove cardboard cover from floor-mount cabinet.
2. Cut band as shown.
3. Remove top packing spacer and corrugated corner supports. (See Figure 2-4 for Step 1 to Step 3.)

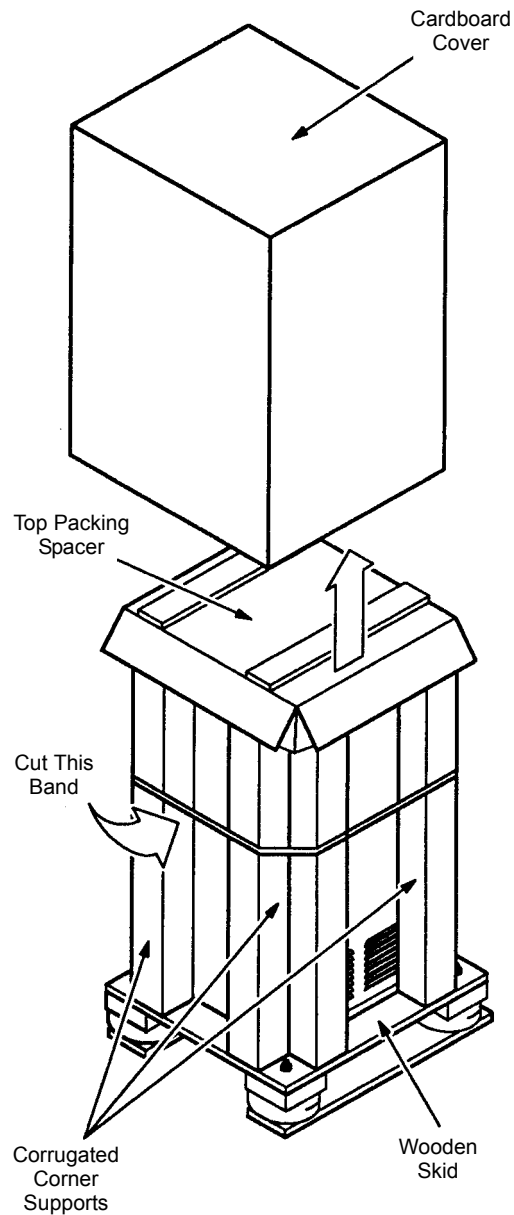

Figure 2-4 Remove Cardboard Cover

4. Remove antistatic bag. Do not discard bag, it will be reinstalled to protect equipment during installation (see Figure 2-5).

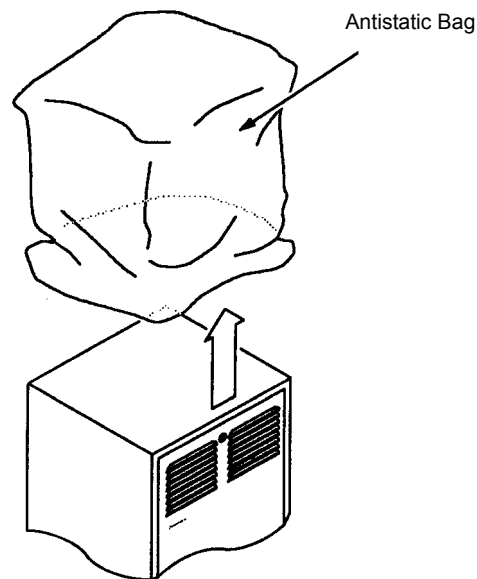

Figure 2-5 Remove Antistatic Bag

5. Depending on cabinet type, either open or remove front and rear doors to gain access to the four (4) bolts securing the floor-mount cabinet to the wooden skid. Remove the bolts and nuts as shown (see Figure 2-6).

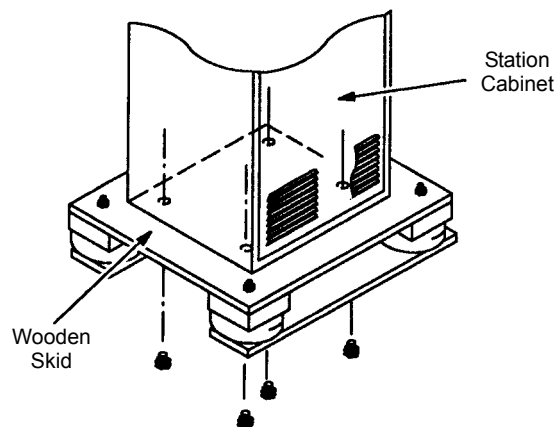

Figure 2-6 Remove Bolts and Nuts

6. Use hoist to lift the floor-mount cabinet from the skid. Remove skid and return floor-mount cabinet to floor.
7. Replace antistatic bag over base station/repeater (if desired) to provide protection during installation.

2.2.2 Mounting Procedures

2.2.2.1 Introduction

The base stations/repeaters can be mounted in the selected cabinet or rack, and may be installed by following the procedures below. However, the following three scenarios require special mounting procedures:

- Customer plans to mount equipment in a rack or cabinet.
- Customer orders two base stations/repeaters in a single rack.
- Customer requires slide rail assembly.

2.2.2.2 Installing Racks

In a typical installation, the rack is bolted to a concrete floor to provide stability.

The following procedure describes the steps necessary to bolt the rack to a concrete floor. Be sure to check with local authorities to verify that the following procedure conforms to local building codes and regulations **before permanently installing the rack**.

1. Carefully align the rack at the desired anchoring location.
2. Use the rack mounting foot as a template and mark the location of the six 19 mm (3/4 in) diameter mounting holes. All six anchoring positions must be used.
3. Move the rack aside, drill holes in the concrete floor, and install the mounting anchors (RAM RD-56 anchors recommended) per instructions provided with the anchors. Make sure that none of the anchors comes in contact with the reinforcing wire mesh buried in the concrete; the rack must be electrically isolated from any other equipment or materials at the site.
4. Align the rack with the installed anchors and lightly secure the rack to the floor using the proper mounting hardware. Do not tighten the mounting hardware at this time.
5. Check the vertical plumb of the rack. Also check that the top is level. Use shims (flat washers or flat aluminum plates) as necessary under the rack mounting foot to achieve vertical plumb and horizontal level.
6. Tightly secure the rack to the floor anchors making sure that it remains vertically plumb and horizontally level.
7. After all debris is removed and cement dust is cleared away, remove whatever protective covering has been placed on the equipment, including the antistatic bag.

 <p>Caution</p>	<p>Cement dust from concrete flooring is harmful to electronic equipment and wiring. Make sure that the rack and any collocated equipment are protected prior to drilling holes in the concrete floor. Use a tarpaulin, cloth, or plastic sheeting to cover exposed equipment. (The rack should be already covered with an antistatic bag; do not remove the bag at this time.) Use a vacuum while drilling the holes to minimize the spread of concrete dust. Carefully clean up any accumulated dust and debris from the anchor installation before uncovering the equipment.</p>
--	---

2.2.2.3 Mounting Floor-Mount Cabinets

Each cabinet bottom is pre-drilled with four (4) mounting holes to allow attachment to the site floor. If installing on a concrete floor, use the cabinet as a template, mark the hole locations, and follow the procedures above for anchoring equipment racks. If installing on a wooden floor, use lag bolts and washers (customer supplied) to secure the cabinet to the floor.

2.2.2.4 Transferring Equipment from Shipping Container to Rack or Cabinet

As mentioned under Equipment Unpacking and Inspection, a base station/repeater can be shipped in a box. Upon delivery, the equipment must be removed from the container and transferred to a rack or cabinet.

NOTE: Cabinets and racks must have mounting rails and hole spacing compatible with EIA Universal 48.3 cm (19 in) specifications. Cabinets must provide adequate ventilation (as detailed under Equipment Ventilation) and must meet the following criteria:

- 41.3 cm (16.25 in) deep
- 48.3 cm (19 in) wide
- 13.4 cm (5.25 in) high
- Two mounting rails 5 cm (2 in) from front of cabinet with front mounting holes 5.7 cm (2.25 in) apart (center to center).

Contact Motorola Engineering for specific questions regarding mounting equipment in customer-supplied cabinets.

2.2.2.5 Installing Slide Rail Assembly in a Motorola Cabinet

Referring to Figure 2-7, perform the following procedure to install slide rail.

On a bench-top, working on one side of the slide rail assembly at a time:

1. Remove the Inner-Slide Rail from the slide assembly (left and right) by depressing the Slide Locking Latch and sliding the Inner-Slide Rail out from the slide assembly.
2. Install the Inner-Slide Rail (left) on the Power Supply side by:
 - removing the two bottom screws from the base station/repeater power supply EMI cover, and
 - installing the Inner-Slide Rail (left) with the supplied screws.
3. Install the Inner-Slide Rail (right) on the PA side using the holes in the PA casing.
4. Attach each Outer-Slide Rail to a Cabinet Bracket with supplied screws.

NOTE: The left and right Cabinet Brackets are identical.

The Locking Tab of each Outer-Slide Rail must face towards the rear of the cabinet.

Working in the cabinet:

5. The cabinet must have a set of vertical cabinet rails in the back as well as the front. If there is no set in the back, these must be installed. The back rail is installed the same as the front rail, with the supplied screws.
6. Install each assembled Cabinet Bracket (with attached Outer-Slide Rail) to the appropriate side of the cabinet. The U-shaped cutout of the Cabinet Bracket must face up.
7. Slide the base station/repeater (with an Inner-Slide Rails mounted on each side) into the Outer-Slide Rails in the cabinet; an audible snap is heard. Continue sliding the base station/repeater in until the base station/repeater is fully seated.
8. Secure the base station/repeater to the cabinet front rails with the supplied screws.

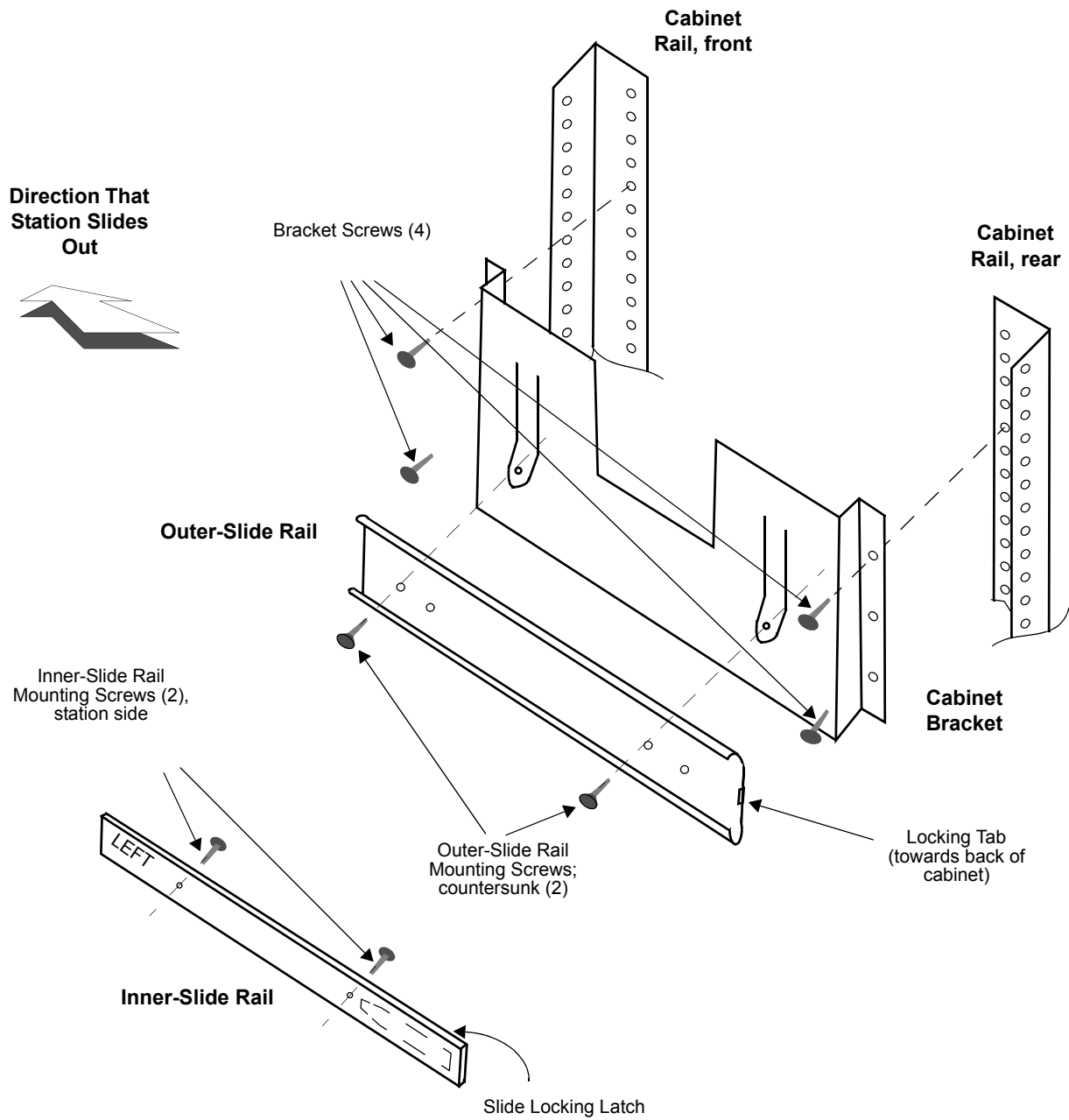

Figure 2-7 Slide Rail Installation for Motorola Cabinet (Left Side Shown)

NOTE: The left-side slide rail assembly is shown, as viewed from the front of the cabinet. The left side is a mirror image of the right side.

The middle-slide rail is not shown (for clarity).

2.2.2.6 Installing Slide Rail Assembly in a Non-Motorola Cabinet

Referring to Figure 2-8, perform the following procedure to install non-Motorola slide rail.

On a bench-top, working on one side of the slide rail assembly at a time:

1. Remove the Inner-Slide Rail from the slide assembly (left and right) by depressing the Slide Locking Latch and sliding the Inner-Slide Rail out from the slide assembly.
2. Install the Inner-Slide Rail (left) on the Power Supply side by:
 - removing the two bottom screws from the base station/repeater power supply EMI cover, and
 - installing the Inner-Slide Rail (left) with the supplied screws.
3. Install the Inner-Slide Rail (right) on the PA side using the holes in the PA casing.
4. Attach each Outer-Slide Rail to the cabinet Brackets with supplied screws. Only use the lower slot of each bracket. Leave the screws loose; they will be tightened when the brackets are mounted in the cabinet (in step 7).

NOTE: The left and right Cabinet Bracket sets are identical.

The Locking Tab of each Outer-Slide Rail must face towards the rear of the cabinet.

Working in the cabinet:

5. Install a cage nut in line with clearance hole in Threaded Strip prior to fitting the Front Bracket to the front cabinet rail. This nut is required for mounting the base station/repeater (in step 9). The cage nuts are provided with the cabinet.
6. Fit the Short Bracket and Long Bracket (with attached Outer-Slide Rail) to the Front and Rear Cabinet Rails using the Bracket Mounting Screws and Threaded Strips.
7. Tighten the Outer-Slide Rail hardware after positioning the Outer-Slide Rail front side in line with the inner surface of the Front Cabinet Rails.
8. Slide the base station/repeater (with an Inner-Slide Rail mounted on each side) into the Outer-Slide Rails in the cabinet; an audible snap is heard. Continue sliding the base station/repeater in until the base station/repeater is fully seated.
9. Secure the base station/repeater to the Front Cabinet Rails with the supplied Base Station/ Repeater Mounting Screws.

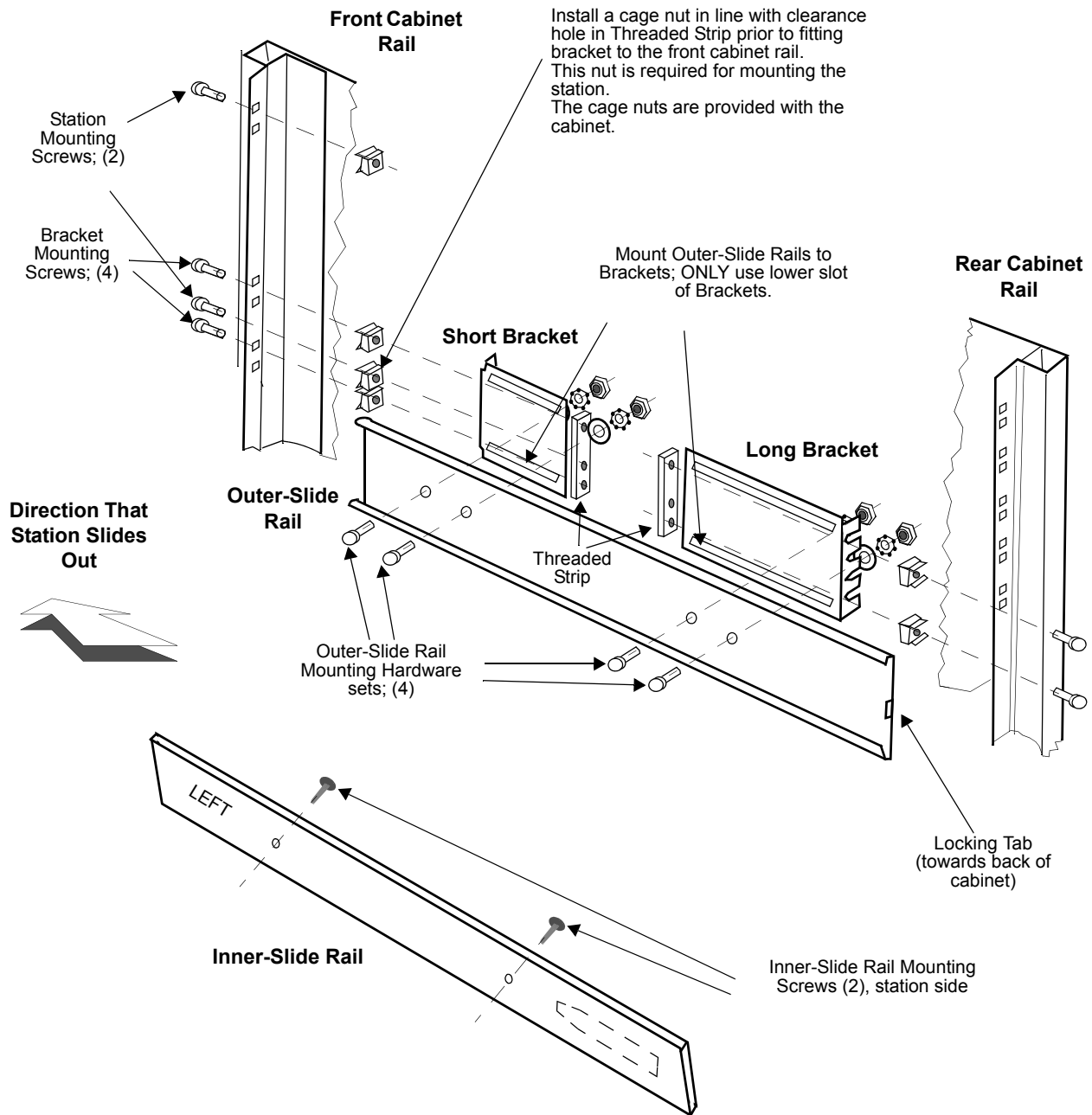

Figure 2-8 Slide Rail Installation for Non-Motorola Cabinet (Left Side Shown)

NOTE: The left-side slide rail assembly is shown, as viewed from the front of the cabinet. The left side is a mirror image of the right side.

The middle-slide rail is not shown (for clarity).

2.3 Electrical Connections

After the base station/repeater equipment has been mechanically installed, electrical connections must be made. This involves making the following connections to:

- power supply,
- antenna coax cables,
- system cables, and
- wireline telephone lines.

IMPORTANT: When installing option boards, ensure that an Electro-Static Discharge (ESD) cable is connected (via banana plug) to the hole in the front-right handle of the base station/repeater when installing option boards. Otherwise, the option boards may be damaged. See Figure 2-9.

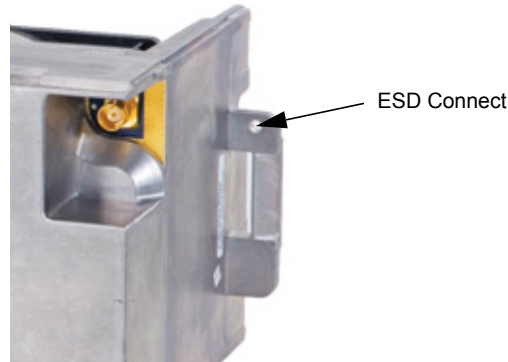

Figure 2-9 ESD Connect

There are also electrical connections associated with maintenance and troubleshooting of the base station/repeater. These connectors are located on the front of the SCM (see Service Connections section for position of these connectors).

Figure 2-10 shows the position of the base station/repeater external connectors located at the rear of the base station/repeater.

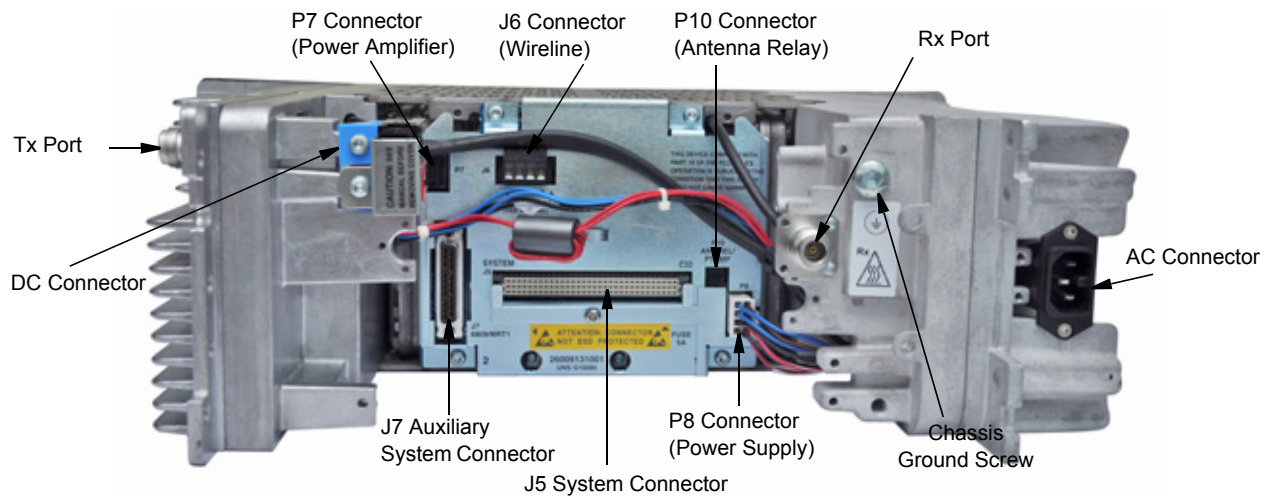



Figure 2-10 Location of External Connectors at Rear of Base Station/Repeater

2.3.1 Power Supply Connections

2.3.1.1 AC Input Power Connection

 Caution	<p>Do not apply AC power to the base station/repeater at this time. Make sure that the circuit breaker associated with the AC outlet is turned to OFF.</p> <p>The AC socket-outlet must be installed near the equipment and must be easily accessible.</p>
---	--

Each base station/repeater is shipped with an 2.5 m (8 ft) 3-conductor line cord. Figure 2-10 shows the AC line cord connector. Insert the plug into an appropriate grounded outlet.

The North American line cord is equipped with a NEMA 5–15 plug, intended for 110/120 VAC operation. The optional European line cord (X189AA) is equipped with a “Schuko” style CEE VII (7) plug, intended for 220/240 VAC operation. See Table 2-4 for plugs for different countries.

Table 2-4. Plugs for Different Countries

Location	Option Number
Europe	X189AA
U.K.	X162AD
Australia	X191AD

If an alternate line cord is required, obtain a line cord employing “HAR” flexible cord with fittings approved by the safety testing agency in the end-use country.

2.3.1.2 DC Input Power Connection

For DC-only operation, the DC source power is connected to the base station/repeater through the battery backup connector shown in Figure 2-10. The operation is also described in “Battery Connection” on page 2-19. The DC source must be located in the same building as the base station/repeater, and it must meet the requirements of a SELV circuit.

The DC power cable (CA01520AA) can be used for the base station/repeater.

 WARNING	<p>Ensure that the appropriate voltage is connected with a nominal 28.6 VDC (21.0 to 32.0 VDC).</p>
---	--

2.3.1.3 Ground Connection

The base station/repeater is equipped with a ground screw located on the rear of the base station/repeater Power Supply module. Connect the ground screw to the site ground point. The size of the wire used for this connection must be 8 AWG minimum.

 <p>Caution</p>	<p>Refer to Motorola Quality Standards Fixed Network Equipment Installation manual, R56 (6881089E50) for complete information regarding lightning protection.</p> <p>The base station/repeater is to be connected to a battery supply that is in accordance with the applicable electrical codes for the end use country; for example, the National Electrical Code ANSI/NFPA No. 70 in the U.S.</p>
--	--

2.3.1.4 Battery Connection

Battery backup interface offers the capability of connecting to battery backup power in the event of an AC power line failure.

The battery backup system is connected to the base station/repeater through the red and black connector mounted at the rear of the base station/repeater. The connector has a cover with the label stating the below.

CAUTION: See manual before removing cover.

This label directs the technician to read the information provided below:

This battery backup system must have, at a minimum, a disconnect relay controlled by an AC fail detector.

 <p>WARNING</p>	<p>DO NOT connect a battery directly to the base station/repeater. Damage to batteries as well as to the base station/repeater may occur. Batteries must be connected to the base station/repeater through an Argus Technologies Battery Reverting Charger, Model #010-523-20 (Motorola Model #L1884) for 24 V charging systems. These systems were developed specifically for this interface and tested by Motorola for proper base station/repeater operation. Damage resulting from use of any other charging systems will void the warranty. Refer to qualified sales/service representative for charger ordering information.</p>
--	---

 <p>Caution</p>	<p>The base station/repeater is to be connected to a battery supply that is in accordance with the applicable electrical codes for the end use country; for example, the National Electric Code ANSI/NFPA No.70 for the U.S.</p>
--	--

Cables are supplied with the charging option. **Do not make connections directly from the base station/repeater to the storage battery.** Connect as shown in Figure 2-11.

Required input power:

- Voltage - 28.4 VDC
- Current - 13.0 Amps

Both positive and negative terminals must be protected with appropriate fast acting fuses. Secondary circuitry must be SELV type and be installed nearby, preferable in the same building. All installations shall be carried out by trained service personnel only.

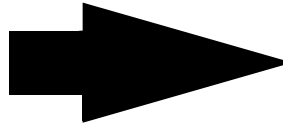

DC input Connector located at rear of the station for hooking up the **Battery backup system**.



Figure 2-11 Making Connections to Storage Battery

 Caution	Connector ESD cover must be in place when Battery Backup cable is not in use – to prevent exposure to live contacts.
--	--

2.3.2 RF Antenna Connections

The transmit and receive antenna RF connections are made using two separate N-type connectors. Coax cables from the receive and transmit antennas must be connected to the two N-type connectors. The position of these connectors is shown in Figure 2-10.

In the case where an optional Antenna Relay is used on the base station/repeater, the coax cable from the single transmit/receive antenna is connected to the middle N-type connector of the Antenna Relay.

2.3.3 System Cable Connections

System connections are made through one or both of the following connectors:

- Auxiliary System Connector
- System Connector

The location of the Auxiliary System Connector and System Connector on the base station/repeater rear panel is shown in Figure 2-10.

Table 2-5 provides a description of commonly used J7 Auxiliary System Connector pins.

Table 2-6 to Table 2-8 provides a description of the J5 System Connector pins.

NOTE: (*) Indicates an active low signal.

Table 2-5. J7 Auxiliary System Connector Pins

Pin #	Pin Assignment	Input/Output	To/From	Signal Characteristics
1	Tx Audio	I	J3-B30, J4-A17	Transmit Audio – Nominal input level is 80 mVrms for 60% deviation with scaling factor set to 100%. 600 Ω input impedance.
2	GPI_1	I/O	J3-C32, J4-A16	Output Logic Low: 0.5 VDC max Output Logic High: Open Collector with 10K pull-up to 5 V Input Logic Low: 0 to 0.8 VDC Input Logic High: 3.0 to 14 VDC
3	Aux Rx Audio	O	J3-A19	Auxiliary Receiver Audio – Nominal output level is 330 mVrms with a 60% deviation receive signal. 1000 Ω output impedance
4	GPIO_2	I/O	J3-B32, J4-C18	Output Logic Low: 0.5 VDC max Output Logic High: Open Collector with 10K pull-up to 5 V Input Logic Low: 0 to 0.8 VDC Input Logic High: 3.0 to 14 VDC
5	GPIO_10	I/O	J3-A17, J4-B17	Output Logic Low: 0.5 VDC max Output Logic High: Open Collector with 10K pull-up to 5 V Input Logic Low: 0 to 0.8 VDC Input Logic High: 3.0 to 14 VDC
6	GPIO_9	I/O	J3-A13, J4-A4	Output Logic Low: 0.5 VDC max Output Logic High: Open Collector with 10K pull-up to 5 V Input Logic Low: 0 to 0.8 VDC Input Logic High: 3.0 to 14 VDC
7	Rx Audio	O	J3-A30, J4-C16	Auxiliary Receiver Audio – Nominal output level is 330 mVrms with a 60% deviation receive signal. 1000 Ω output impedance.
8	GPIO_6	I/O	J3-A32, J4-B19	Output Logic Low: 0.5 VDC max Output Logic High: Open Collector with 10K pull-up to 5 V Input Logic Low: 0 to 0.8 VDC Input Logic High: 3.0 to 14 VDC
9	GND			
10	GPIO_7	I/O	J3-C30, J4-A20	Output Logic Low: 0.5 VDC max Output Logic High: Open Collector with 10K pull-up to 5 V Input Logic Low: 0 to 0.8 VDC Input Logic High: 3.0 to 14 VDC
11	GPI_1*	I/O	J3-C32, J4-A16	Output Logic Low: 0.5 VDC max Output Logic High: Open Collector with 10K pull-up to 5 V Input Logic Low: 0 to 0.8 VDC Input Logic High: 3.0 to 14 VDC
12	GPIO_7	I/O	J3-C30, J4-A20	Output Logic Low: 0.5 VDC max Output Logic High: Open Collector with 10K pull-up to 5 V Input Logic Low: 0 to 0.8 VDC Input Logic High: 3.0 to 14 VDC
13	Tx Data	I	J3-B29, J4-A19	Transmit Data/PL/DPL – Nominal input level is 80 mVrms for 20% deviation with scaling factor set to 100%. 600 Ω input impedance.
14	Reserved			
15	GPIO_3	I/O	J3-B31, J4-A18	Output Logic Low: 0.5 VDC max Output Logic High: Open Collector with 10K pull-up to 5 V Input Logic Low: 0 to 0.8 VDC Input Logic High: 3.0 to 14 VDC

Table 2-5. J7 Auxiliary System Connector Pins (Continued)

Pin #	Pin Assignment	Input/Output	To/From	Signal Characteristics
16	GND			
17	GND			
18	GND			
19	GND			
20	Fused 14.2VDC			1 Amp max
21	GPIO_8	I/O	J3-C29, J4-A12	Output Logic Low: 0.5 VDC max Output Logic High: Open Collector with 10K pull-up to 5 V Input Logic Low: 0 to 0.8 VDC Input Logic High: 3.0 to 14 VDC
22	Emph Tx Audio	I	J3-A29, J4-B12	Emphasized Transmit Audio – Nominal input level is 80 mVrms for 60% deviation with scaling factor set to 100%. 600 Ω input impedance.
23	GPI_4	I/O	J3-A31, J4-A10	Output Logic Low: 0.5 VDC max Output Logic High: Open Collector with 10K pull-up to 5 V Input Logic Low: 0 to 0.8 VDC Input Logic High: 3.0 to 14 VDC
24	GPIO_5	I/O	J3-C31, J4-B10	Output Logic Low: 0.5 VDC max Output Logic High: Open Collector with 10K pull-up to 5 V Input Logic Low: 0 to 0.8 VDC Input Logic High: 3.0 to 14 VDC
25	GPIO_6	I/O	J3-A32, J4-B19	Output Logic Low: 0.5 VDC max Output Logic High: Open Collector with 10K pull-up to 5 V Input Logic Low: 0 to 0.8 VDC Input Logic High: 3.0 to 14 VDC

Table 2-6. J5 System Connector, Row A Pins

Pin #	Pin Assignment	Input/ Output	To/From	Signal Characteristics
1	Reserved	O	–	–
2	Reserved	O	J1-C31, J2-C31	–
3	N/C	O	–	–
4	AC Fail	O	P8-5, J1-C29, J2-C29, J3-C24	TTL output, active high
5	Reserved	I	J1-C28, J2-C28	–
6	Reserved	I	J1-C27, J2-C27	–
7	Reserved	I	J1-C26, J2-C26	–
8	Reserved	I	J1-C25, J2-C25	–
9	Reserved	I	J1-C24, J2-C24	–
10	Reserved	O	J1-C23, J2-C23	–
11	Reserved	O	J1-C22, J2-C22	–
12	Reserved	O	J1-B25, J2-B25	–
13	Antenna Relay	O	P10-1, J3-C26	OCO, 200 mA, active low
14	Reserved	O	J3-C19	–
15	N/C	–	–	–
16	N/C	–	–	–
17	Reserved	I	J3-C16	–
18	Accessory 14.2 VDC	O	P8 pins 3, 4 (through F2)	+14.2 VDC
19	GND	–	Station ground	–
20	5 VDC	O	P8 pins 7, 8	+5.1 ± 0.25 VDC
21	Reserved	O	J3-C12	–
22	Spare	I	J1-C11, J2-C11	
23	N/C	–	–	–
24	N/C	–	–	–
25	N/C	–	–	–
26	Ext PTT-	I	J1-C7, J2-C7	Opto-Isolated PTT Input
27	GND	–	Station ground	–
28	Reserved	I/O	J1-C6, J2-C6	–
29	Ext PTT+	I	J1-C5, J2-C5	Opto-Isolated PTT Input
30	AC Fail Relay (NO)	O	J1-C4, J2-C4	Normally Open Relay Contact
31	GND	–	Station ground	–
32	Accessory 14.2 VDC	O	P8 pins 3, 4 (through F2)	+14.2 VDC

Table 2-7. J5 System Connector, Row B Pins

Pin #	Pin Assignment	Input/Output	To/From	Signal Characteristics
1	Reserved	O	J1-B32, J2-B32	–
2	Reserved	O	J1-B31, J2-B31	–
3	Carrier Operated Relay (Common)	O	J1-B30, J2-B30	Common Relay Contact
4	Carrier Detect Switch	O	J1-B29, J2-B29, J3-B24	TTL output, active high
5	Reserved	I	J1-B28, J2-B28	–
6	Reserved	I	J1-B27, J2-B27	–
7	Reserved	I	J1-B26, J2-B26	–
8	Reserved	I	J3-B25	–
9	Reserved	I/O	J1-B24, J2-B24	–
10	N/C	–	N/C	–
11	Reserved	I/O	J1-B22, J2-B22	–
12	Reserved	I/O	J1-B23, J2-B23	–
13	Reserved	–	N/C	–
14	Reserved	I	J1-B19, J2-B19, J3-B19, J7-14	–
15	GND	–	Station ground	–
16	N/C	–	–	–
17	N/C	–	–	–
18	Accessory 14.2 VDC	O	P8 pins 3, 4 (through F2)	+14.2 VDC
19	GND	–	Station ground	–
20	5 VDC	O	P8 pins 7, 8	+5.1 ± 0.25 VDC
21	Reserved	O	J1-B12	–
22	N/C	–	–	–
23	N/C	–	–	–
24	N/C	–	–	–
25	N/C	–	–	–
26	N/C	I	J1-B7, J2-B7	–
27	GND	–	Station ground	–
28	Reserved	O	J4-C10	–
29	AC Fail Relay (Common)	O	J1-B4, J2-B4	Common relay contact
30	Reserved	O	J4-A9	–
31	GND	–	Station ground	–
32	Accessory 14.2 VDC	O	P8 pins 3, 4 (through F2)	+14.2 VDC

Table 2-8. J5 System Connector, Row C Pins

Pin #	Pin Assignment	Input/Output	To/From	Signal Characteristics
1	Reserved	O	J1-A32, J2-A32	–
2	Reserved	O	J1-A31, J2-A31, J3-A26	–
3	Carrier Operated Relay (Normally Open)	O	J1-A30, J2-A30	Normally Open Relay Contact
4	Reserved	O	J1-A29, J2-A29	–
5	Reserved	I	J1-A28, J2-A28	–
6	Reserved	I	J1-A27, J2-A27, J3-B26	–
7	Reserved	I	J1-A26, J2-A26	–
8	Reserved	I	J3-A25	–
9	RF Relay Control Out (Auxiliary I/O)	O	J1-B5, J2-B5	OCO, 200 mA, 40 V, active high
10	Ext PTT* Out (Auxiliary I/O)	I	J1-A23, J2-A23, J3-A23	TTL input
11	RSSI	O	J1-A22, J2-A22, J3-A22	Typically 0.5 VDC for -120 dBm to 4.5 VDC for -40 dBm carrier. Variation with carrier level at approximately 50 mV/dBm.
12	Reserved	I/O	J1-A24, J2-A24	–
13	N/C	–	–	–
14	Aux Rx Audio	O	J1-A19, J2-A19, J3-A19, J7-3	–
15	GND	–	Station ground	–
16	GND	–	Station ground	–
17	Reserved	O	J1-A16, J2-A16, J3-A16	–
18	Accessory 14.2 VDC	O	P8 pins 3, 4 (through F2)	+14.2 VDC
19	GND	–	Station ground	–
20	5 VDC	O	P8 pins 7, 8	+5.1 ± 0.25 VDC
21	Reserved	O	J3-A12	–
22	N/C	–	–	–
23	N/C	–	–	–
24	GPIO_10	I/O	J1-A9, J2-A9, J3-A17	TTL input/output
25	N/C	–	–	–
26	N/C	–	–	–
27	GND	–	Station ground	–
28	Reserved	I	J4-C12	–
29	GPIO_9	I/O	J1-A4, J2-A4, J3-A13	TTL input/output
30	Reserved	I	J4-A11	–
31	GND	–	Station ground	–
32	Accessory 14.2 VDC	O	P8 pins 3, 4 (through F2)	+14.2 VDC

2.3.4 Base Station/Repeater Maintenance Connections

Table 2-9 provides a description of the maintenance connections located on the front of the SCM.

Table 2-9. SCM Connectors

Connector Name	Connector Type	Purpose
Service	USB Type B	Service Computer connection. This connector is accessible with front cover in place. VBUS (+5 V) is not provided on the USB connector.
Mic	RJ45 (8 Pin)	Microphone connection. Compatible with microphone GMMN4063 or equivalent (older model, GMN6147). This connector is accessible with front cover in place. NOTE: The Mic port is only supported in analog mode regardless of the microphone used. For older microphone model (GMN6147), the three control buttons for speaker volume control, Rx monitor and Intercom control functions are not supported.
Speaker	4P4C	Speaker connection. Compatible with Service Speaker HSN1006 or equivalent (older model, HSN1000). This connector is accessible with front cover in place. NOTE: The Speaker port is only supported in analog mode regardless of the speaker used.
Ethernet	RJ45 (8 Pin) (Vertical)	Network connection to Trunking Controller. The front cover must be removed to access this connector. An optional extension cable can also be used to route this input to the rear of the station. Alternatively, the Ethernet cable can also be routed out through the slots provided in the front panel.
Ext Ref	BNC (Vertical)	External reference input. The front cover must be removed to access this connector. Alternatively, an extension cable can be used to route this input to the rear of the station.

2.4 Post Installation Checklist

After the base station/repeater equipment has been mechanically installed and all electrical connections have been made, power may now be applied and the base station/repeater checked for proper operation.

2.4.1 Applying Power

Before applying power to the base station/repeater, make sure all boards are securely seated in the appropriate connectors on the backplane interface board and that all RF cables are securely connected.

Turn ON the circuit breaker controlling the AC outlet that is supplying power to the base station/repeater Power Supply Module, or switch on the DC-supply to a base station/repeater with a DC Power Supply Module.

- Changing Fuse

To replace the base station/repeater fuse for failure, perform the following steps:

1. Turn off base station/repeater power at source (e.g., AC breaker).
2. Remove fuse cover plate located on the backplane interface board shield by unscrewing one M4 screw.
3. Pull defective fuse carefully with a pair of small needle nose pliers.
4. Replace new fuse (6583049X16) carefully with a pair of small needle nose pliers.

 <p>Caution</p>	<p>For continued protection of the base station/repeater against risk of fire, replace the fuse only with the same type and rating of fuse.</p>
--	---

5. Restore power to the base station/repeater.

2.4.2 Verifying Proper Operation

Operation of the base station/repeater can be verified by:

- observing the state of the six LEDs located on the front bezel, and
- exercising radio operation.

 <p>Caution</p>	<p>Some base station/repeater components can become extremely hot during base station/repeater operation. Turn off all power to the base station/repeater, and wait until sufficiently cool before touching the base station/repeater.</p>
--	--

2.4.2.1 Front Bezel LEDs

After booting up the base station/repeater, the six LEDs (Power/Status, Tx Slot 1, Tx Slot 2, Rx Slot 1, Rx Slot 2 and the Mode LEDs) flashes in unison.

The general status and condition of the MTR3000 Base Station/Repeater can be obtained by observing the eight LED indicators on the front bezel. Table 2-10 shows the LED symbols and their meaning while Table 2-11 identifies the information conveyed via the LED indicators.

Table 2-10. Front Bezel LED indicators







LED	Definition
	Status
	Tx Slot 1 (for label number 1) Tx Slot 2 (for label number 2)
	Rx Slot 1 (for label number 1) Rx Slot 2 (for label number 2)
	Mode
	Ethernet Link
	Reference

Table 2-11. MTR3000 Software and Hardware Controlled LEDs

LED Function Name	LED Color	LED State	Status Indication
Power/Status, Tx Slot 1, Tx Slot 2, Rx Slot 1, Rx Slot 2 Mode	Amber	Flashing	Station booting up
	Blue		
Power/Status	Off	Off	Station Off
	Green	Flashing	Station Operating Normally, with DC power
		Solid	Station Operating Normally, with AC power
	Red	Flashing	Station Operational – Minor Alarm
		Solid	Station Not Operational – Major Alarm
	Amber	Flashing	Station in Service Mode
Solid		Station is Disabled (Dekeyed)	
Tx Slot 1 Tx Slot 2	Off	Off	Transmitter is not transmitting
	Green	Solid	Transmitter is transmitting
		Flashing	Transmitter is transmitting, but at reduced power
Rx Slot 1 Rx Slot 2	Off	Off	Receiver qualifier has not been met
	Green	Solid	Receiver qualifier has been met
Mode	Off	Off	Analog Mode (FM)
	Blue	Solid	Digital Mode (2 Slot TDMA, 4FSK)
	Blue	Flashing	DMM feature is active, but no calls are currently being processed.
Ethernet Link	Off	Off	No Ethernet connection
	Green	Solid	Linked
		Flashing	Network traffic
Reference	Off	Off	No external reference is present
	Green	Solid	Training process is completed and the calibration data has been written to the EEPROM, or an external reference is present after training (which the base station/repeater has phase locked to).
	Amber	Solid	Locked to external reference, and training is in progress

NOTE: The RDAC application will be needed when the Status LED is red (solid or flashing). This status indicates a minor or major alarm. The RDAC application is used to identify the specific alarm and probable diagnosis to aid in identifying the FRU at fault.

If the Reference LED remains amber for more than ten minutes during the alignment, then verify the integrity of the source used to train the base station/repeater's internal reference. If the integrity of the source is verified to be good, then the SCM will need to be replaced.

2.4.2.2 Exercising Radio Operation

This may be carried out when an external speaker and microphone are connected to the SCM.

The kit number for the speaker is HSN1006. The external speaker requires an adaptor cable with the part number 0185180U01.

 <p>Caution</p>	<p>Using a speaker other than the recommended HSN1006 or older HSN1000 may result in the station blowing a fuse.</p>
--	--

The kit number for the noise-cancelling microphone is GMMN4063 or older GMN6147.

2.5 Optimization

After the base station/repeater and ancillary equipment have been mechanically installed, properly cabled, and power applied, the equipment must then be optimized; that is, before placing the base station/repeater in operation. Optimizing is performed through the Customer Programming Software (CPS) with the kit number, RVN5115 and a USB cable (NAG: CLN8665A, EMEA: DDN9957) is required.

After the base station/repeater is operational, the base station/repeater's codeplug data must be copied to a PC-compatible computer.

2.5.1 Optimizing Tasks

Optimization involves the following tasks:

1. Reading the base station/repeater codeplug from the base station/repeater (this ensures a match between the base station/repeater serial number (resident in the codeplug) and the serial number (part of the customized base station/repeater codeplug data) that is written back to the base station/repeater (see task 5).
2. Customizing the base station/repeater codeplug and saving the data to the base station/repeater.
3. Aligning the base station/repeater for:
 - Modulation Limit
 - Speaker Level
 - Station Reference
 - MTR2000 PA Calibration
 - Receiver Squelch Adjust
 - Wireline Transmit Level

- Wireline Squelch Level
 - Wireline Receive Level
 - Wireline Rx Equalization
4. Performing post-optimization procedures.
 5. Writing the customized codeplug to the base station/repeater codeplug.

For details on these tasks, refer to the Customer Programming Software (CPS) Online Help.

 WARNING	A minimum of a 10-minute warm up period prior to aligning the station reference is required with the 800/900 MHz base station/repeater. Failure to comply will result in an inaccurate reference frequency alignment.
--	---

2.5.2 Copying Base Station/Repeater Codeplug Data To a PC-compatible Computer

 Caution	A copy of each base station/repeater's codeplug data must be made on an IBM-PC compatible computer. This is done through the Customer Programming Software (CPS).
--	---

2.6 Installing Base Station/Repeater Hardware Options

When a base station/repeater is ordered with an Antenna Relay or External Preselector option, the respective module is attached to the base station/repeater when delivered.

When a base station/repeater is ordered with an External Double Circulator option, this circulator is provided in a peripheral tray.

In the case where an option is later added to the base station/repeater, it can be installed according to the information provided in the Ancillary Equipment sections of the appropriate Instruction manual. Also refer to the Troubleshooting section for information on tuning the External Preselector.

Notes

Chapter 3 Base Station/Repeater Operation

3.1 Description

This section describes the LED indicators and connectors provided on the base station/repeater.

The set of LEDs indicate the operational status of the base station/repeater.

There are two sets of connectors for devices external to the base station/repeater:

- One set connects to external devices to enable full operation of the base station/repeater. These are located at the back of the base station/repeater.
- Another set connects to external devices for servicing the base station/repeater. These are located on the SCM.

3.1.1 LED Indicators

A set of eight LEDs is located on the base station/repeater front bezel. The position of the eight LEDs on the front bezel is shown in Figure 3-1. These LEDs indicate the status of the base station/repeater during normal operation.



Figure 3-1 Front Bezel LEDs and Connectors

For further information on the states of these LEDs, refer to “Front Bezel LEDs” on page 2-28.

3.1.2 External Device Connections

Refer to Section 2.3: Electrical Connections for the position of the base station/repeater external connectors and line cord, located on the back panel.

The connection to external devices on the back panel is the J7 Auxiliary System Connector. The connector is a 25-pin connector used for connecting to an external device such as a trunking controller, tone remote adaptor or phone patch. See Figure 2-10 for the location of the connector.

The connection to external devices on the front of the SCM is the BNC connector. The connector allows the base station/repeater to be connected to a 5 MHz or 10 MHz external reference signal.

Figure 3-1 shows the location of the connectors on the front of the SCM and Figure 3-2 shows the position of the BNC connector on the SCM.

3.1.3 Service Connections

Service ports and LEDs are located on the front of the SCM.

Figure 3-2 shows the position of the connectors on the SCM.

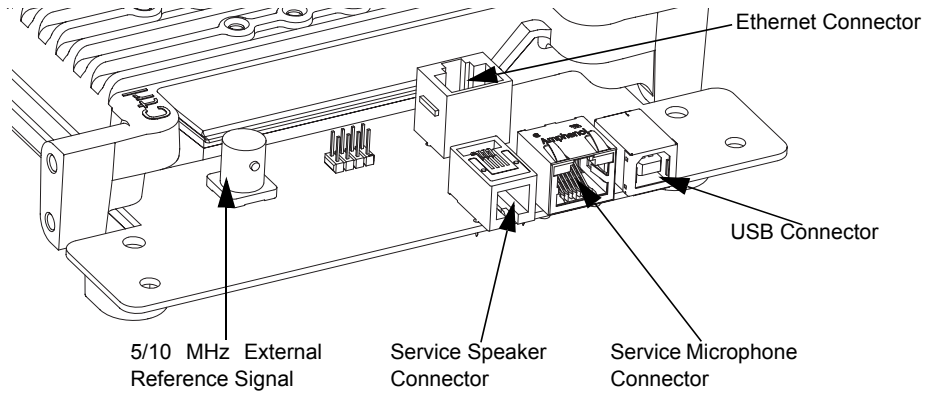

Figure 3-2 SCM Connectors

The service ports include connectors for:

- 5/10 MHz External Reference Signal
- Ethernet Connector
- Service Speaker Connector
- USB Connector
- Service Microphone Connector

Appendix A EMEA Regional Warranty, Service and Technical Support

A.1 Warranty and Service Support

Motorola offers long term support for its products. This support includes full exchange and/or repair of the product during the warranty period, and service/ repair or spare parts support out of warranty. Any "return for exchange" or "return for repair" by an authorized Motorola Dealer must be accompanied by a Warranty Claim Form. Warranty Claim Forms are obtained by contacting an Authorized Motorola Dealer.

A.1.1 Warranty Period and Return Instructions

The terms and conditions of warranty are defined fully in the Motorola Dealer or Distributor or Reseller contract. These conditions may change from time to time and the following notes are for guidance purposes only.

In instances where the product is covered under a "return for replacement" or "return for repair" warranty, a check of the product should be performed prior to shipping the unit back to Motorola. This is to ensure that the product has been correctly programmed or has not been subjected to damage outside the terms of the warranty.

Prior to shipping any radio back to the appropriate Motorola warranty depot, please contact Customer Resources (Refer to page A-3). All returns must be accompanied by a Warranty Claim Form, available from your Customer Services representative. Products should be shipped back in the original packaging, or correctly packaged to ensure no damage occurs in transit.

A.1.2 After Warranty Period

After the Warranty period, Motorola continues to support its products in two ways.

1. Motorola's Managed Technical Services (MTS) offers a repair service to both end users and dealers at competitive prices.
2. MTS supplies individual parts and modules that can be purchased by dealers who are technically capable of performing fault analysis and repair.

A.2 European Radio Support Centre (ERSC)

The ERSC Customer Information Desk is available through the following service numbers:

Austria:	08 00 29 75 41	Italy:	80 08 77 387
Belgium:	08 00 72 471	Luxemburg:	08 00 23 27
Denmark:	80 88 05 72	Netherlands:	08 00 22 45 13
Finland:	08 00 11 49 910	Norway:	80 01 11 15
France:	08 00 90 30 90	Portugal:	08 00 84 95 70
Germany:	08 00 18 75 240	Spain:	90 09 84 902
Greece:	00 80 04 91 29 020	Sweden:	02 07 94 307
UK:	08 00 96 90 95	Switzerland:	08 00 55 30 82
Ireland:	18 00 55 50 21	Iceland:	80 08 147

Or dial the European Repair and Service Centre:
Tel: +49 30 6686 1555

Please use these numbers for repair enquiries only.

A.3 Piece Parts

Some replacement parts, spare parts, and/or product information can be ordered directly. If a complete Motorola part number is assigned to the part, it is available from Motorola Radio Products and Solutions Organization (RPSO). If no part number is assigned, the part is not normally available from Motorola. If the part number is appended with an asterisk, the part is serviceable by Motorola Depot only. If a parts list is not included, this generally means that no user-serviceable parts are available for that kit or assembly.

Orders for replacement parts, kits and assemblies should be placed directly on Motorola's local distribution/dealer organization or via Motorola Online at: <http://emeaonline.motorola.com>

* The Radio Products and Solutions Organization (RPSO) was formerly known as the Radio Products Services Division (RPSD) and/or the Accessories and Aftermarket Division (AAD).

A.4 Technical Support

Motorola Product Services is available to assist the dealer/distributors in resolving any malfunctions which may be encountered.

North Europe - Stephen Woodrow
Telephone: +44 (0) 1256 488 082
Fax: +44 01256 488 080
Email: CSW066@motorola.com

Central and East Europe - Siggy Punzenberger
Telephone: +49 (0) 6128 70 2342
Fax: +49 (0) 6128 95 1096
Email: TFG003@motorola.com

Russia and Belarus - Andrey Nagornykh
Telephone: +7 495 787 8910
Fax: +7 495 785 0185
Email: MWCB47@motorola.com

Germany - Customer Connect Team
Telephone: +49 (0) 30 6686 1539
Fax: +49 (0) 30 6686 1916
Email: cgiss.emea@europe.mot.com

Middle East and Africa - Wayne Holmes
Telephone: +49 (0)6126 957 6237
Fax: +49 (0)6126 957 6826
Email: wayne.holmes@motorola.com

Italy - Ugo Gentile
Telephone: +39 02 5220 7825
Fax: +39 02 5220 7810
Email: Ugo.Gentile@motorola.com

France - Armand Roy
Telephone: +33 1 6935 7868
Fax: +33 1 6935 7808
Email: armand.roy@motorola.com

France - Laurent Irrmann
Telephone: +33 1 6935 7866
Fax: +33 1 6935 7808
Email: laurent.irrmann@motorola.com

A.5 Further Assistance From Motorola

You can also contact the Customer Help Desk through the following web address.
<http://www.motorola.com/feedback>

Notes

Appendix B Commercial Warranty

NOTE: This is only applicable to LACR and NAG.

Limited Warranty

MOTOROLA COMMUNICATION PRODUCTS

I. What This Warranty Covers And For How Long

MOTOROLA INC. ("MOTOROLA") warrants the MOTOROLA manufactured Communication Products listed below ("Product") against material defects in material and workmanship under normal use and service for the period of time from the date of purchase as scheduled below:

Base Station/Repeater	Two (2) Years
Product Accessories	One (1) Year

Motorola will at its option and at no charge either repair the defective Product (with new or reconditioned parts), replace it (with a new or reconditioned Product), or refund the purchase price of the defective Product during the warranty period provided it is returned before the expiration of the warranty period and in accordance with the terms of this warranty. Replaced Product, parts or boards are warranted for the balance of the original applicable warranty period. All replaced Product, parts of boards shall become the property of MOTOROLA.

This express limited warranty is extended by MOTOROLA to the original end user purchasing the Product for commercial, industrial or governmental use only and is not assignable or transferable to any other party. This is the complete warranty for the Product manufactured by MOTOROLA. MOTOROLA assumes no obligations or liability for additions or modifications to this warranty unless made in writing and signed by an officer of MOTOROLA. Unless made in a separate agreement between MOTOROLA and the original purchaser, MOTOROLA does not warrant the installation, maintenance or service of the Product.

MOTOROLA is not responsible in any way for any ancillary equipment not furnished by MOTOROLA which is attached to or used in connection with the Product, or for operation of the Product with any ancillary equipment, and all such equipment is expressly excluded from this warranty. Because each system which may use the Product is unique, MOTOROLA disclaims liability for range, coverage, or operation of the system in part or as a whole under this warranty.

II. General Provisions

This warranty sets forth the full extent of MOTOROLA'S responsibilities regarding the Product. Repair, replacement or refund of the purchase price, at MOTOROLA'S option, is the exclusive remedy. THIS WARRANTY IS THE COMPLETE WARRANTY FOR THE PRODUCT AND IS GIVEN IN LIEU OF ALL OTHER WARRANTIES. MOTOROLA DISCLAIMS ALL OTHER WARRANTIES OR CONDITIONS, EXPRESS OR IMPLIED, INCLUDING WITHOUT LIMITATION, IMPLIED WARRANTIES OF MERCHANTABILITY AND FITNESS FOR A PARTICULAR PURPOSE. IN NO EVENT SHALL MOTOROLA BE LIABLE FOR DAMAGES IN EXCESS OF THE PURCHASE PRICE OF THE PRODUCT, FOR ANY COMMERCIAL LOSS; INCONVIENCE; LOSS OF USE, TIME, DATA, GOOD WILL, REVENUES, PROFITS OR SAVINGS; OR OTHER SPECIAL, INCIDENTAL, INDIRECT, OR CONSEQUENTIAL DAMAGES IN ANY WAY RELATED TO OR ARISING FROM THE SALE OR USE OF THE PRODUCT.

III. How To Get Warranty Service

You must provide proof of purchase (bearing the date of purchase and Product item serial number) in order to receive warranty service and deliver or send the Product item, transportation and insurance prepaid, to an authorized warranty service location before the expiration of the warranty period. Warranty service will be provided by Motorola through one of its authorized warranty service locations. If you first contact the company which sold you the Product, it can facilitate your obtaining warranty service. You can also open a *Contact Us* case on Motorola Online (<http://www.motorola.com/businessonline>) for LACR, or call Motorola at 1-888-567-7347 US/Canada for NAG.

IV. What This Warranty Does Not Cover

This warranty does not cover:

- A. Defects or damage resulting from use of the Product in other than its normal customary or authorized manner.
- B. Defects or damage from misuse, accident, liquid, lightning, neglect or act of God.
- C. Defects or damage from testing, maintenance, installation, alteration, modification, or adjustment not provided or authorized in writing by MOTOROLA.
- D. Breakage or damage to antennas unless caused directly by defects in material or workmanship.
- E. A Product subjected to unauthorized Product modifications, disassemblies or repairs (including, without limitation, the addition to the Product of non-Motorola supplied equipment) which adversely affect performance of the Product or interfere with Motorola's normal warranty inspection and testing of the Product to verify any warranty claim.
- F. Product which has had the serial number removed or made illegible.
- G. Freight costs to ship the product to the repair depot.
- H. Batteries (because they carry their own separate limited warranty) or consumables.
- I. Customer's failure to comply with all applicable industry and OSHA standards.
- J. A Product which, due to illegal or unauthorized alteration of the software/firmware in the Product, does not function in accordance with MOTOROLA's published specifications or the FCC type acceptance labeling in effect for the Product at the time the Product was initially distributed from MOTOROLA.
- K. Scratches or other cosmetic damage to Product surfaces that does not affect the operation of the Product.

L. Normal and customary wear and tear.

V. Governing Law

This Warranty is governed by the laws of the State of Illinois, USA.

Notes

Appendix C LACR Replacement Parts Ordering and Motorola Service Centers

C.1 Replacement Parts Ordering

C.1.1 Basic Ordering Information

When ordering replacement parts or equipment information, the complete identification number should be included. This applies to all components, kits, and chassis. If the component part number is not known, the order should include the number of the chassis or kit of which it is a part, and sufficient description of the desired component to identify it.

C.1.2 Motorola Online

Motorola Online users can access our online catalog at <http://www.motorola.com/businessonline>

To register for online access:

- Have your Motorola Customer number available.
- Please go to <http://www.motorola.com/businessonline> and click on "Sign Up Now."
- Complete form and submit it.
- Contact your BDM to complete set-up and it will be done within 24 to 48 hours.

C.2 Motorola Service Centers

C.2.1 Servicing Information

If a unit requires further complete testing, knowledge and/or details of component level troubleshooting or service than is customarily performed at the basic level, please send the radio to a Motorola Service Center as listed below.

C.2.2 Motorola de México, S.A.

Bosques de Alisos 125
Col. Bosques de las Lomas CP 05120
México D.F.
México
Tel: (5) 257-6700

C.2.3 Motorola de Colombia, Ltd.

Carrera 7 No. 71-52
Bogota - Colombia
Tel: (571) 376-6990

Notes

Appendix D NAG Replacement Parts Ordering and Motorola Service Centers

D.1 Replacement Parts Ordering

D.1.1 Basic Ordering Information

When ordering replacement parts or equipment information, the complete identification number should be included. This applies to all components, kits, and chassis. If the component part number is not known, the order should include the number of the chassis or kit of which it is a part, and sufficient description of the desired component to identify it. The MOTOTRBO MTR3000 Base Station/Repeater Basic Service Manual (Motorola publication part number 68007024096) includes complete parts lists and part numbers.

D.1.2 Motorola Online

Motorola Online users can access our online catalog at

<http://www.motorola.com/businessonline>

To register for online access, please call 1-800-422-4210 (for U.S. and Canada Service Centers only). International customers can obtain assistance at <http://www.motorola.com/businessonline>.

D.1.3 Mail Orders

Mail orders are only accepted by the U.S. Federal Government Markets Division (USFGMD):

Motorola Inc.
7031 Columbia Gateway Drive
3rd Floor - Order Processing
Columbia, MD 21046
U.S.A.

D.1.4 Telephone Orders

Radio Products and Solutions Organization*
(United States and Canada)
7:00 AM to 7:00 PM (Central Standard Time)
Monday through Friday (Chicago, U.S.A.)
1-800-422-4210
1-847-538-8023 (United States and Canada)

U.S. Federal Government Markets Division (USFGMD)
1-877-873-4668
8:30 AM to 5:00 PM (Eastern Standard Time)

D.1.5 Fax Orders

Radio Products and Solutions Organization*
(United States and Canada)
1-800-622-6210
1-847-576-3023 (International)

USFGMD
(Federal Government Orders)
1-800-526-8641 (For Parts and Equipment Purchase Orders)

D.1.6 Parts Identification

Radio Products and Solutions Organization*
(United States and Canada)
1-800-422-4210

D.1.7 Product Customer Service

Radio Products and Solutions Organization (United States and Canada)
1-800-927-2744

* The Radio Products and Solutions Organization (RPSO) was formerly known as the Radio Products Services Division (RPSD) and/or the Accessories and Aftermarket Division (AAD).

D.2 Motorola Service Centers

D.2.1 Servicing Information

If a unit requires further complete testing, knowledge and/or details of component level troubleshooting or service than is customarily performed at the basic level, please send the radio to a Motorola Service Center as listed below.

D.2.2 Motorola Service Center

Motorola Repair
2214 Galvin Drive
Elgin, IL 60123
Tel: 1-800-221-7144

D.2.3 Motorola Federal Technical Center

4395 Nicole Drive
Lanham, MD 20706
Tel: 1-800-969-6680
Fax: 1-800-784-4133

D.2.4 Motorola Canadian Technical Logistics Center

Motorola Canada Ltd.
8133 Warden Avenue
Markham, Ontario, L6G 1B3
Tel: 1-800-543-3222
Fax: 1-888-331-9872 or 1-905-948-5970

Appendix E MOTOTRBO Base Station/Repeater – EME ASSESSMENT

E.1 Executive Summary

The Electromagnetic Energy (EME) compliance boundaries in a typical system configuration of the Motorola MOTOTRBO MTR3000 Base Station/Repeater described in the following are derived.

Compliance is established with respect to the applicable limits defined in the ICNIRP guidelines [1], the United States regulations [2]-[3], and in the CENELEC Standards EN50384:2002 [5] and EN50385:2002 [6]. These standards and regulations apply to *occupational* and *general public* EME exposure.

The assessment was carried out using a computational method described in the CENELEC Standard EN50383:2002 [4], which is referenced by the EN50385:2002, and this report has been drafted in accordance with its requirements. Thus the assessment and report address the European Radio and Telecommunications Terminal Equipment (R&TTE) Directive requirements concerning EME exposure.

The following table provides the compliance distances for *general public* and *occupational-type* exposure, for the antenna considered in this analysis, based on a typical system configuration:

Compliance distances	Antenna front (Andrew mod. DB408)	Ground level (20 m below antenna)
General public exposure	6 m	Always compliant
Occupational-type exposure	1.2 m	Always compliant

E.2 Exposure Prediction Model

E.2.1 Exposure in Front of the Antenna

The cylindrical-wave model defined in Clause 8.3.4 of the EN50383:2002 standard is applied to determine the compliance boundaries for workers and general public for a typical system configuration of the MOTOTRBO MTR3000 Base Station/Repeater.

Figure E-1 Reference frame for the point of interest (POI) cylindrical co-ordinates

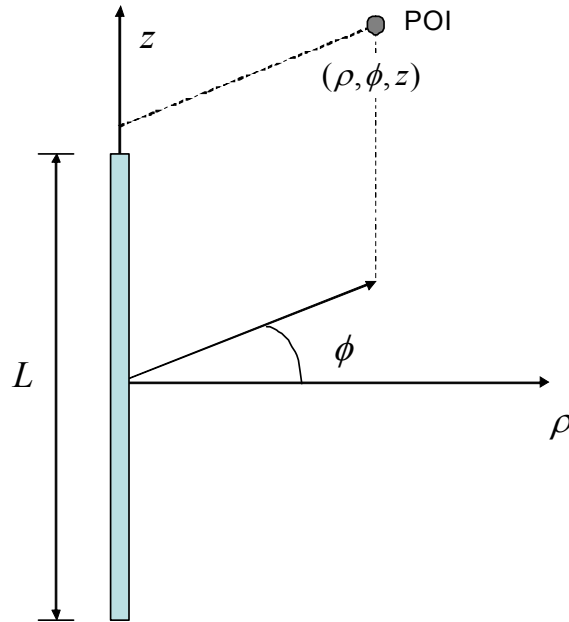

Per the reference frame in Figure E-1, the cylindrical-wave model is applicable in the volume described in cylindrical co-ordinates (ρ, ϕ, z) as follows:

$$\lambda/4 \leq \rho \leq \min\{r_c, 2L^2/\lambda\}, \quad |\phi| \leq \delta/2, \quad |z| \leq L/2,$$

where λ is the wavelength in m , L is the antenna largest dimension in m , δ is the angle in degrees defining the -3 dB beamwidth of a directional antenna (for an omni-directional antenna δ is equal to 360 degrees), and

$$r_c = G_A \cdot L \cdot \delta / 720$$

where G_A is the antenna maximum gain relative to an isotropic antenna. The power flux density (S), expressed in W/m^2 , is calculated as follows:

$$S_{cyl} = \frac{P}{\pi L \rho} \frac{180}{\delta} \quad (1)$$

where P is the input power to the antenna. In the region where,

$$\lambda/4 \leq r_c \leq 2L^2/\lambda$$

the power flux density is calculated as the maximum between the cylindrical and spherical-wave models, where the latter is expressed as follows:

$$S_{sph} = \frac{PG_A}{4\pi\rho^2} \quad (2)$$

Spatial power density averaging, which is required by some regulations, is embedded in the cylindrical-wave model formulation, therefore it does not require additional considerations.

E.2.2 Exposure at Ground Level

Several methods can be employed to determine the EME exposure at ground level. Such an assessment is not necessary if the mounting height of the antenna is larger than the compliance distance *in front* of the antenna, computed using the EN50383:2002 methodology outlined in E.2.1. If this is not feasible, then the following approach can be employed.

At ground level exposure occurs in the antenna far-field. The antenna phase center is assumed to be the mounting height. The resulting predictive equation for the power density is:

$$S(d) = (2.56) \frac{P \cdot G(\theta)}{4\pi(H^2 + d^2)} \quad (3)$$

where $G(\theta)$ is the elevation gain pattern, which is approximated by the following expression:

$$G(\theta) = G_A \left| \frac{\sin\left(\frac{k_0 L}{2} \sin\theta\right)}{\frac{k_0 L}{2} \sin\theta} \right|^2 \quad (4)$$

where $k_0 = 2\pi / \lambda$ is the free-space wavenumber and L is the *effective* antenna length yielding the appropriate vertical beamwidth, while H is the antenna height above ground and d is the *point of interest* (POI) distance from the vertical antenna projection to ground (see Figure E-2). The multiplicative factor 2.56 is introduced to enforce near-perfect, in-phase ground reflection as recommended in [2]. In this case, spatial averaging is not carried out to make the EME exposure assessment more conservative.

Figure E-2 Schematic of the ground-level exposure model adopted for the assessment

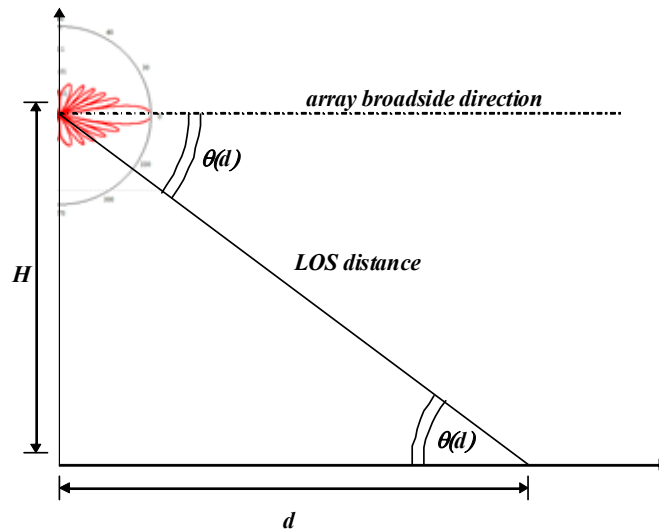

E.3 Typical System Configuration

The MOTOTRBO MTR3000 Base Station/Repeater operates in the frequency ranges 403–470 MHz and 470–524 MHz, with up to five channels transmitting 100 W radio frequency (RF) power. The typical system configuration comprises an omnidirectional array antenna featuring 6–10 dBd gain, installed at or above 20 m from ground level, and fed by the MTR3000 through a combiner characterized by a typical 3 dB transmission loss, and a 30 m 7/8" coaxial cable characterized by a typical 2.7 dB/100m loss at 400 MHz, resulting in a total 3.9 dB transmission loss. Based on these characteristics, the RF power at the antenna input is about 200 W.

Since shorter antennas provide a conservative EME exposure assessment from equation (1), the parameters of a typical 6.6 dBd antennas are employed. Such an antenna (e.g., Andrew DB408) would exhibit a typical elevation beamwidth of about 14 degrees.

E.4 Exposure Limits

Based on the MTR3000 operating frequency range, the most conservative power density limits are those defined in the ICNIRP guidelines [1]. They are 10.1 W/m^2 for occupational exposure, and 2.02 W/m^2 for general public exposure. They will be used for the EME exposure assessment.

E.5 EME Exposure Evaluation

E.5.1 Exposure in Front of the Antenna

The assessment is based on the following characteristics of the Andrew DB408 antenna:

$$G_A = 10^{\frac{6.6+2.15}{10}} = 7.5 \quad P = 200 \text{ W} \quad \delta = 360^\circ \quad L = 2.7 \text{ m}$$

The compliance boundary distance is computed, from equation (1), as follows:

$$\rho = \frac{P}{\pi L S_{\text{lim}}} \frac{180}{\delta}$$

where S_{lim} is the applicable power density limit. For occupational exposure, this equation gives:

$$\rho_{\text{OCC}} = \frac{200 \text{ W}}{\pi \cdot 2.7 \text{ m} \cdot 10.1 \text{ W/m}^2} \frac{180}{360} = 1.2 \text{ m}$$

while for general public exposure it gives:

$$\rho_{\text{GP}} = \frac{200 \text{ W}}{\pi \cdot 2.7 \text{ m} \cdot 2.02 \text{ W/m}^2} \frac{180}{360} = 6 \text{ m}$$

E.5.2 Exposure at Ground Level

Since the antenna installation height above ground level in the typical system configuration (20 m) is larger than either of the compliance boundaries determined in E.5.1, the EME exposure at ground level is always compliant with the exposure limits defined in the ICNIRP guidelines.

E.6 Compliance Boundary Description

Based on the analysis in section E.5, the compliance boundaries for *occupational* and *general public* exposure are defined as cylinders enclosing the antenna (see Figure E-3), extending 75 cm (one wavelength) above and below the physical antenna, with radii:

Occupational exposure:

$$\rho_{OCC} = 1.2 \text{ m}$$

General Public exposure:

$$\rho_{GP} = 6 \text{ m}$$

Figure E-3 Compliance boundary for general public (GP) and occupational (OCC) exposure

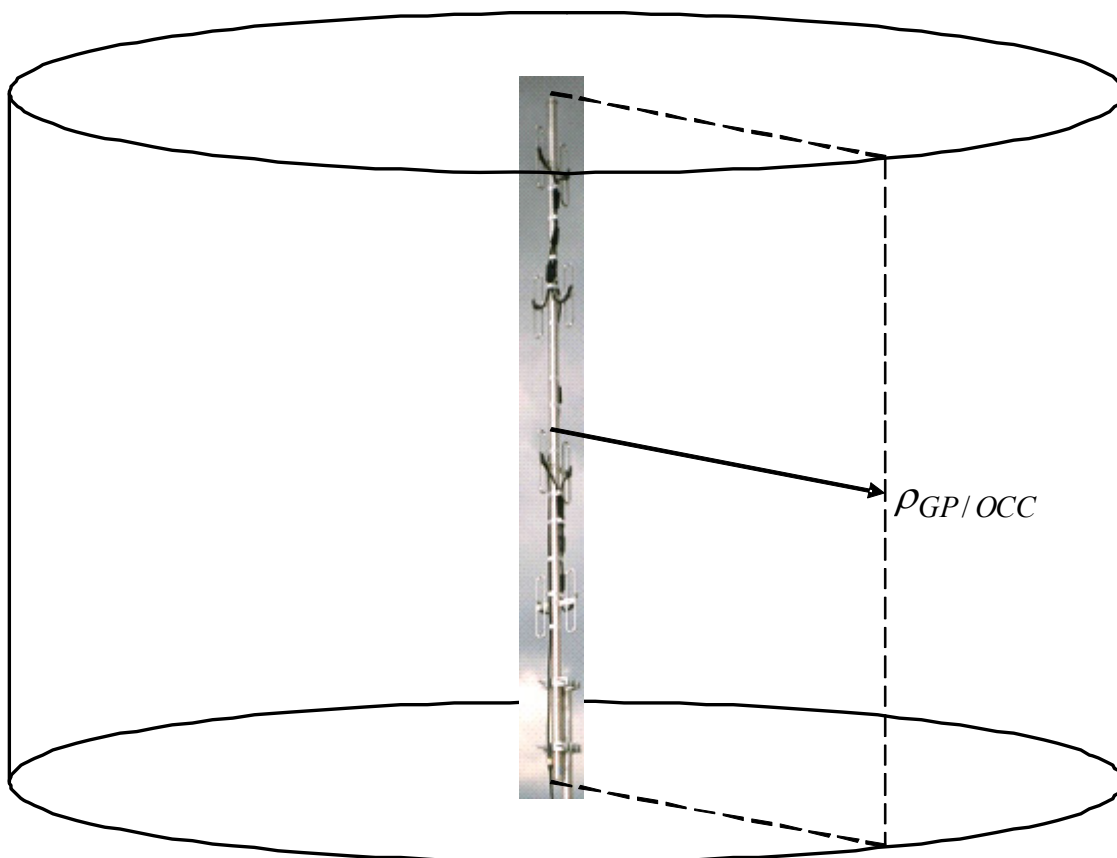

E.7 References

1. International Commission on Non-Ionizing Radiation Protection (ICNIRP), "Guideline for Limiting Exposure to Time-Varying Electric, Magnetic, and Electromagnetic Fields," Health Physics, vol. 74, no. 4, pp. 494-522, April 1998.
2. United States Federal Communication Commission, "Evaluating compliance with FCC guidelines for human exposure to radio frequency electromagnetic fields," OET Bulletin 65, Ed. 97-01, Section 2 (Prediction Methods), August 1997.
3. US Code of Federal Regulations, Title 47, Volume 1, Sec. 1.1310 Radio frequency radiation exposure limits (Revised as of October 1, 2003).
http://edocket.access.gpo.gov/cfr_2003/octqtr/47cfr1.1310.htm.

4. EN 50383:2002. Basic standard for the calculation and measurement of electromagnetic field strength and SAR related to human exposure from radio base stations and fixed terminal stations for wireless telecommunications system (110 MHz - 40 GHz). CENELEC (European Committee for Electrotechnical Standardization).
5. EN 50384:2002. Product standard to demonstrate the compliance of radio base stations and fixed terminal stations for wireless telecommunication systems with the basic restrictions or the reference levels related to human exposure to radio frequency electromagnetic fields (110 MHz - 40 GHz). Occupational. CENELEC (European Committee for Electrotechnical Standardization).
6. EN 50385:2002. Product standard to demonstrate the compliances of radio base stations and fixed terminal stations for wireless telecommunication systems with the basic restrictions or the reference levels related to human exposure to radio frequency electromagnetic fields (110 MHz - 40 GHz). General public. CENELEC (European Committee for Electrotechnical Standardization).



Radio Communication Solutions

株式会社 ジャパンエニックス

JAPAN ENIX CO.,LTD.

- 本 社 東京都品川区南品川 2-7-18 TEL 03-5715-2351
- 関 西 支 店 大阪市西区千代崎 1-24-11 TEL 06-6583-7700
- 札幌営業所 名古屋営業所
- 仙台営業所 九州営業所

<https://www.jenix.co.jp/> 営業所住所はこちら ▶



MOTOROLA

Motorola, Inc.
1301, E. Algonquin Rd.
Schaumburg, IL 60196-1078, U.S.A.

MOTOROLA and the Stylized M Logo are registered in the U.S. Patent and Trademark Office. All other product or service names are the property of their respective owners.
© 2010 by Motorola, Inc.
All rights reserved. Printed in the U.S.A.
December 2010.

www.motorola.com/mototrbo



68007024098-E